



Classic Heat Pump Installation & Operation Manual

Vertical Wall-Mount Heat Pumps

MODELS AVPA 24-30-36-42-48-60, HVPA 24-30-36-42-49-60 & HVPSA36-42-49-60
(Includes units with the GreenWheel® ERV, the GreenCube® ERV and Hot Gas Reheat)



Model AVPA36



Manufactured By:

How To Use This Manual

This manual is intended to be a comprehensive guide to the installation of the Marvair® Classic line of vertical packaged heat pumps. It contains installation, troubleshooting, maintenance, warranty, and application information. The information contained in this manual is to be used by the installer as a guide only. This manual does not supersede or circumvent any applicable national or local codes. For information on the efficiency, cooling and heating performance, please refer to the Classic AVPA and HVPA Product Data Sheets. The most current version of all Marvair literature can be found on our website at www.marvair.com.

If you are installing the Classic, first read Chapter 1 and scan the entire manual before beginning the installation as described in Chapter 2. Chapter 1 contains general, descriptive information and provides an overview which can speed up the installation process and simplify troubleshooting.

If a malfunction occurs, follow this troubleshooting sequence:

1. Make sure you understand how the Classic works (Chapters 1 & 3).
2. Identify and correct installation errors (Chapter 2).
3. Refer to the troubleshooting information in Chapter 4.
4. Identify defective part(s). (Chapter 5).

If you are still unable to correct the problem, contact the Factory at 1-800-841-7854 for additional assistance.

Please read the following “Important Safety Precautions” before beginning any work. Failure to follow these rules may result in death, serious bodily harm, property damage and damage to the equipment.

Important Safety Precautions

1. USE CARE when LIFTING or TRANSPORTING equipment.
2. TRANSPORT the UNIT UPRIGHT. Laying it down on its side may cause oil to leave the compressor and breakage or damage to other components.
3. TURN ELECTRICAL POWER OFF AT THE breaker or fuse box BEFORE installing or working on the equipment. LINE VOLTAGES ARE HAZARDOUS or LETHAL.
4. OBSERVE and COMPLY with ALL applicable PLUMBING, ELECTRICAL, and BUILDING CODES and ordinances.
5. SERVICE may be performed ONLY by QUALIFIED and EXPERIENCED PERSONS.



- * Wear safety goggles when servicing the refrigeration circuit
- * Beware of hot surfaces on refrigerant circuit components
- * Beware of sharp edges on sheet metal components
- * Use care when recovering or adding refrigerant

6. Use COMMON SENSE - BE SAFETY-CONSCIOUS

This is the safety alert symbol . When you see this symbol on the Classic unit and in the instruction manuals be alert to the potential for personal injury. Understand the signal word DANGER, WARNING and CAUTION. These words are used to identify levels of the seriousness of the hazard.



Failure to comply will result in death or severe personal injury and/or property damage.



Failure to comply could result in death or severe personal injury and/or property damage.



Failure to comply could result in minor personal injury and/or property damage.

IMPORTANT is used to point out helpful suggestions that will result in improved installation, reliability or operation.

 **WARNING**

- If the information in these instructions are not followed exactly, a fire may result causing property damage, personal injury or loss of life.
- Read all instructions carefully prior to beginning the installation. Do not begin installation if you do not understand any of the instructions.
- Improper installation, adjustment, alteration, service or maintenance can cause property damage, personal injury or loss of life.
- Installation and service must be performed by a qualified installer or service agency in accordance with these instructions and in compliance with all codes and requirements of authorities having jurisdiction.

INSTALLER: Affix the instructions on the inside of the building adjacent to the thermostat.
END USER: Retain these instructions for future reference.

TABLE OF CONTENTS

Chapter 1 - Classic Description & Specifications

1.1	General Description.....	5
1.2	Air Flow, Weights and Filter Sizes.....	6
1.3	General Operation.....	7
1.4	Controls - Standard - PC Board.....	9
1.5	Options.....	14
1.6	Economizer.....	15

Chapter 2 - Installation

2.1	Equipment Inspection.....	17
2.2	Installation Requirements.....	17
2.3	Installation Materials.....	19
2.4	Porting and Duct Work.....	21
2.5	Fresh Air Hood Adjustment.....	22
2.6	Bracket Installation.....	22
2.7	Mounting the Unit.....	23
2.8	Electrical Connections.....	24

Chapter 3 - Start-Up

3.1	Check-Out of Cooling Cycle.....	27
3.2	Check-Out of Heating Cycle.....	28
3.3	Discharge Air Adjustment for Modulating Hot Gas Reheat (HGR) Valve.....	28
3.4	Ventilation System Set Up.....	30

Chapter 4 - Troubleshooting

4.1	Overview.....	32
4.2	Failure Symptoms Guide.....	33
4.3	Compressor Troubleshooting.....	34
4.4	Electric Heat Control.....	35

Chapter 5 - Electrical Schematics

5.1	Electrical Schematics.....	36
-----	----------------------------	----

Chapter 6 - Periodic Maintenance Requirements

6.1	Scheduled Maintenance.....	42
-----	----------------------------	----

Chapter 7 - Warranty Information

7.1 Standard Product Warranty	43
Exploded Views & Parts Lists	44
Appendix A - Installation Instructions of Field Installed Electric Heat	44

FIGURES

Figure 1	PC Control Board	14
Figure 2	Enthalpy Sensor Temperature Control Points.....	16
Figure 3	Fresh Air Hood Damper	22
Figure 4	Classic Heat Pump Wall Mounting Detail	23
Figure 5a	Humidity Control Wiring Detail.....	26
Figure 5b	Thermostat Connection Diagram.....	26
Figure 6	Temperature Sensor Wires - Modulating HGR Valve	29
Figure 7	Desired Temperature Set Point - Modulating HGR Valve.....	29
Figure 8	Damper Adjustment	30
Figure 9	Damper Air Path	31
Figure 10	Typical Configuration for Single Element Heater.....	35
Figure 11a	Typical 1ø Electrical Schematic Diagram Classic Heat Pump (Models AVPA) with Manual Outside Air Damper	37
Figure 11b	Typical 208/230v. 3ø Electrical Schematic Diagram Classic Heat Pump (Models AVPA)	38
Figure 11c	Typical 460v. 3ø Electrical Schematic Diagram Classic Heat Pumps, Models AVPA, with the PC Control Board	39
Figure 11d	Typical Electrical Schematic Diagram Classic Heat Pump (Models HVPA) with Manual Outside Air Damper	40
Figure 11e	Typical Electrical Schematic Diagram Classic Heat Pump (Models HVP) with Economizer.....	41

TABLES

Table 1a	CFM @ External Static Pressure - AVPA.....	6
Table 1b	CFM @ External Static Pressure - HVPA & HVPSA.....	6
Table 2a	Ship Weight - AVPA.....	6
Table 2b	Ship Weight - HVPA & HVPSA.....	7
Table 3	Filter Sizes - AVPA, HVPA & HVPSA.....	7
Table 4a	Minimum Clearances - AVPA.....	18
Table 4b	Minimum Clearances - HVPA.....	18
Table 5	Voltage Limitations.....	19

Classic Heat Pump Description and Specifications

1.1 General Description

The Marvair® Classic Heat Pumps are high efficiency, vertical wall mounted heat pumps that provide heating, cooling and ventilation for a wide range of applications. Nominal cooling capacities range from 24,000 to 60,000 BTUH. The AVPA Series consists of units with EER's from 9.0 to 9.5.



The HVP Series feature units with EER's of up to 11.50 and quiet operation. Resistance heating are available in all models. Please see appendix A for the installation instructions on field installing electric heaters. HVPSA36-42-49-60 units have 2-stage compressors with first stage cooling approximately 65% of the total cooling capacity. The two stage compressor can reduce energy costs and is able to more precisely match the cooling and dehumidifying capacity of the heat pump with the heat load in the classroom.

Classic heat pumps are designed for easy installation and service. All units have built-in side mounting flanges and are shipped with a bottom support bracket. The unit has been factory charged. Service ports have been provided for field service, if required. All internal wiring is complete.

The Classic heat pumps are available in a wide variety of styles and configurations to meet the various ventilation and cooling requirements. For school classrooms, models are available to comply with the ASHRAE 62-1999 standard, "Ventilation for Acceptable Indoor Air Quality." Where cooling is required during cool or cold weather, e.g., telecommunication shelters, a factory-installed economizer can be used. To insure proper operation and optimum performance, all outside air ventilation packages and the economizer are non-removable, factory installed and tested. Instructions for the HVP models with the GreenWheel® ERV and the GreenPac HGR are included in this manual.

All Classic heat pumps are tested and certified for efficiency and capacity in accordance with the ANSI/AHRI (Air-Conditioning, Heating and Refrigeration Institute) Standard 390-2003 (Single Package Vertical Units). All AVPA and HVPA units meet or exceed the efficiency requirements of ANSI/ASHRAE/IESNA 90.1.2007. Classic heat pumps are listed by ETL and tested to UL standard 1995, 4th Edition. Classic heat pumps are commercial units and are not intended for use in residential applications.

AVPA Model Identification

AVP	S	A	**	HP
Air Source Vertical Package								
Refrigerant R410-A Refrigerant								
Two-Stage Compressor								
Nominal Cooling*								
24 = 24,000 BTUH			30 = 30,000 BTUH		36 = 36,000 BTUH		60 = 60,000 BTUH	
System Type Heat Pump								
Power Supply								
A = 208/230V, 1 Ph, 60 Hz			C = 208/230V, 3 Ph, 60 Hz			D = 460V, 3 Ph, 60 Hz		
Electric Heat (kW)								
000 = No Heat			040 = 4 kW		050 = 5 kW		060 = 6 kW	
			090 = 9 kW		100 = 10 kW		120 = 12 kW	
							150 = 15 kW	
Ventilation Code								
N = 0-15% fresh air with manual damper, no pressure relief								
Y = 0 to 450 cfm* of outside air, field adjustable, manual damper, no pressure relief								
Z = 0 to 450 cfm* of outside air, field adjustable, manual damper, includes pressure relief								
B = Motorized two position damper (open & closed) capable of 0 to 450 cfm* of outside air, includes pressure relief								
C = Economizer - 100% rated airflow of outside air used for cooling when outside conditions are suitable								
H = GreenWheel® Energy Recovery Ventilator								
J = PowerVent with motorized damper. Includes pressure relief.								
Special Option Code								
R = Electric Reheat Dehumidification			U = Scroll Compressor			G = HGR (Hot Gas Reheat)		

HVPA Model Identification

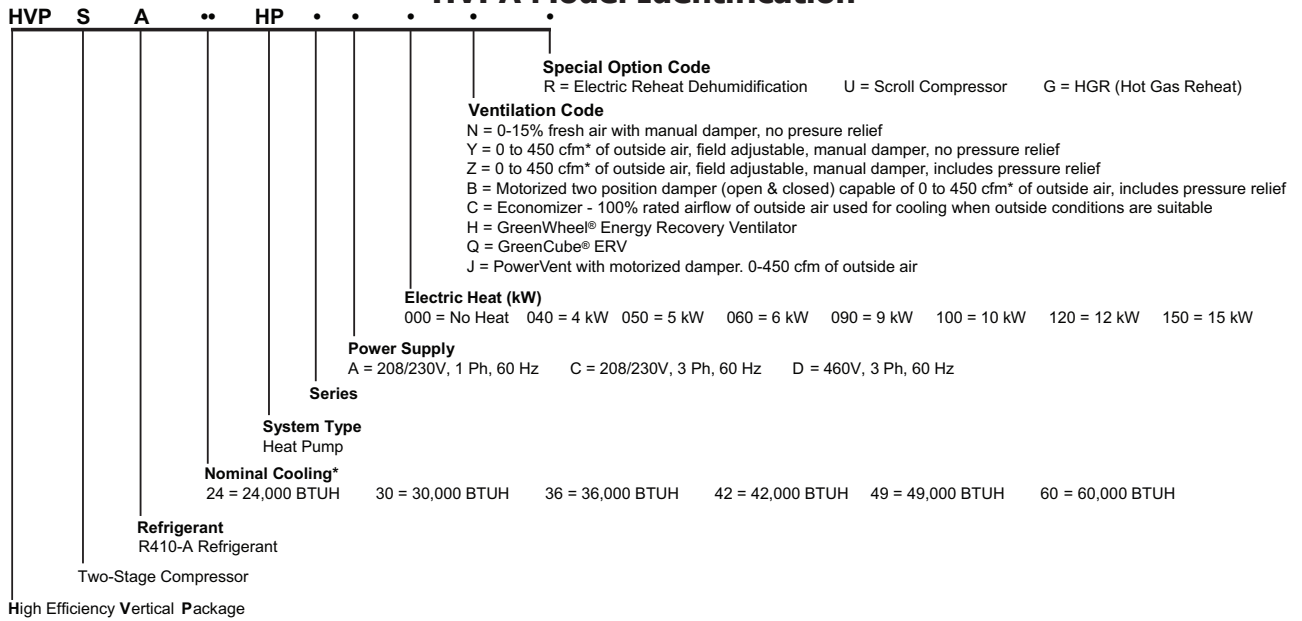

Serial Number Date Code

A = January	E = May	J = September	L = 2000	R = 2004	V = 2008	B = 2012
B = February	F = June	K = October	M = 2001	S = 2005	Y = 2009	C = 2013
C = March	G = July	L = November	N = 2002	T = 2006	Z = 2010	
D = April	H = August	M = December	P = 2003	U = 2007	A = 2011	

1.2 Air Flow, Weights and Filter Sizes.

Table 1a. Air Flow (Cubic Feet per Minute) AVPA

MODEL	External Static Pressure (WET COIL)					
	0.10	0.20	0.25	0.30	0.40	0.50
AVPA24	860	810	740	670		
AVPA30	1100	1000	960	920	810	
AVPA36	1310	1220	1185	1150	1060	
AVPA42		1650	1585	1520	1450	1360
AVPA48		1900	1830	1760	1700	1620
AVPA60		1900	1830	1760	1700	1620

Air flow ratings of 208-230v. Units are at 230v. Air flow ratings of 480 v. units are at 460 volts. Operation of units at a different voltage from the rating point will affect air flow.

Table 1b. Air Flow (Cubic Feet per Minute) HVPA & HVPSA

MODEL	External Static Pressure (WET COIL)					
	0.10	0.20	0.25	0.30	0.40	0.50
HVPA24	800	770	725	680	600	500
HVPA30	1200	1100	1050	1000	900	800
HVPA36/HVPSA36	1290	1170	1115	1060	1000	920
HVPA42/HVPSA42	1500	1360	1295	1230	1160	1070
HVPA48/HVPSA48	1900	1800	1700	1600	1500	1350
HVPA60/HVPSA60	2200	2100	2000	1900	1800	1650

Air flow ratings of 208-230v. Units are at 230v. Air flow ratings of 480 v. units are at 460 volts. Operation of units at a different voltage from the rating point will affect air flow.

Table 2a. Ship Weight (lbs) - Model AVPA

MODEL	24	30/36	42	48	60
Classic with "N" Ventilation Configuration	285	375	515	545	590
Classic with "Y", "Z", "B", "J" & "C" Ventilation Configuration	315	405	545	575	590

Table 2b. Ship Weight (lbs) - Model HVPA & HVPSA

MODEL	24	30/36/42	49	60
Classic with "N" Ventilation Configuration	375	560	610	625
Classic with "Y", "Z", "B", "J" & "C" Ventilation Configuration	405	590	625	640

Table 3. Filter Size (inches)

MODEL	FILTER TYPE	INCHES	MILLIMETERS	PART NUMBER	FILTERS PER UNIT	MERV RATING
AVPA24	Return Air Filter	25 x 16 x 1	635 x 406 x 25	80135	1	7
AVPA30/36 & HVPA24	Return Air Filter	30 x 16 x 1	762 x 406 x 25	80136	1	7
AVPA42/48/60, HVPA30/36/42 & HVPSA36/42	Return Air Filter	36½ x 22 x 1	927 x 559 x 25	80139	1	7
HVPA49/60 & HVPSA49/60	Return Air Filter	18 x 24 x 1	457 x 610 x 25	81199	2	7
	Intake Air Filter*	14 x 14 x 1	356 x 356 x 25	80192	1	N/A
AVPA24/30/36 & HVPA24 with GreenWheel ERV	Return Air Filter	27½ x 13½ x 1	699 x 343 x 25	80769	1	7
	Intake Air Filter*	14 x 14 x 1	356 x 356 x 25	80192	1	N/A
AVPA42/48/60, HVPA30/36/42 & HVPSA36/42 with GreenWheel ERV	Return Air Filter	36½ x 22 x 1	927 x 559 x 25	80139	1	7
	Intake Air Filter*	14 x 14 x 1	356 x 356 x 25	80192	1	N/A

*Units with the GreenWheel ERV

1.3 General Operation

Refrigerant Cycle

The Classic heat pumps use R-410A refrigerant in a conventional vapor-compression refrigeration cycle to transfer heat. In the cooling mode, a double blower assembly blows indoor air across the evaporator (indoor coil). Liquid refrigerant passing through the evaporator is boiled into gas by heat removed from the air. The warmed refrigerant gas enters the compressor where its temperature and pressure are increased. The hot refrigerant gas condenses to liquid as heat is transferred to outdoor air blown across the condenser (outdoor coil) by the condenser fan. Liquid refrigerant is metered into the evaporator through a metering device to repeat the cycle. In the heating mode, the process is reversed.

Models HVPSA have 2-stage compressors with first stage cooling capacity approximately 65% of the total cooling capacity. The 2-stage compressor provides lower start-up amps and is able to match more precisely the cooling capacity of the heat pump with the heat load in the building. The 2-stage is only operational in the cooling mode. A two stage cooling thermostat is required for all 2-stage compressors.

Heating Mode

During heating mode a special reversing valve reverses the flow of refrigerant through the system exchanging the roles of the condenser and evaporator. Now the outdoor coil becomes the evaporator and the indoor coil becomes the condenser. The refrigerant then flows through the outdoor coil, picks up heat and becomes vaporized. The vapor then enters the compressor where it is compressed to a higher temperature. Next it is pumped to the indoor coil where the heat will be released into the room. The compressed refrigerant vapor will condense to its liquid state as it gives up heat. Finally, liquid flows through a metering device into the evaporator where the cycle will be repeated.

Optional electric strip heat is available for all models. Please see Appendix A for instructions on field installation of electric heat.

Ventilation Options

- Manual damper capable of up to 15% of rated airflow of outside air; field adjustable, no pressure relief. **(Standard - Ventilation Configuration N)**
- Manual damper capable of 0 to 450 cfm (maximum of 40% of rated airflow) of outside air; field adjustable, no pressure relief. **(Optional - Ventilation Configuration Y)**
- Manual damper capable of 0 to 450 cfm (maximum of 40% of rated airflow) of outside air; field adjustable, includes pressure relief. **(Optional - Ventilation Configuration Z)**
- Motorized, two position damper (open and closed) capable of 0 to 450 cfm (maximum of 40% of rated airflow) of outside air; includes pressure relief. A 24-volt actuated motor controls the damper from an external input such as: a time clock, CO2 sensor, energy management system or manual switch. **(Optional - Ventilation Configuration B)**
- PowerVent with motorized damper capable of 0-450 cfm of outside air, not to exceed 40% of rated airflow. Includes pressure relief. Ventilation intake and exhaust blowers with single motor controller. Optional second controller for exhaust air. **(Optional - Ventilation Configuration J)**

GreenWheel® ERV Operation (Ventilation Option "H")

The Marvair® GreenWheel® ERV is a total energy (both sensible and latent) wheel that reduces both construction and operating cost while ventilating the classroom to ASHRAE 62-1999 requirements. The use of the GreenWheel ERV reduces the energy load of the outside air. Exhausting stale, inside air keeps indoor pollutants and harmful gases to a minimum. The Marvair GreenWheel ERV has been tested and certified according to ARI Standard 1060.

How It Works

During the summer, cool dry air from the classroom is exhausted through the GreenWheel® ERV to the outside. As the air passes through the rotating wheel, the desiccant becomes cooler and drier. Simultaneously, hot humid air is being pulled across the rotating wheel. The cool, dry desiccant absorbs moisture and heat from the incoming air. The cooler, drier air is mixed with the return air from the classroom and distributed throughout the room.

In the winter, warm moist air is exhausted through the GreenWheel® ERV to the outside. As the air passes through the rotating wheel, the desiccant becomes warmer and absorbs moisture. Simultaneously, cold dry air is being pulled across the rotating wheel. The cold, dry air absorbs heat and moisture from the desiccant. The warmed air is mixed with the return air from the classroom and distributed throughout the room.

Quality Components

The GreenWheel® module consists of a desiccant wheel, two blowers and the drive motor and belt. The two blowers simultaneously pull fresh air from outside and exhaust air from the classroom through the rotating wheel. Two variable speed blowers ensure that up to 450 CFM of outside air can be brought into the room and the indoor air is properly exhausted. Variable speed blowers permit that the desired quantity of outside air is delivered into the room. Optional independent exhaust air blower control allows positive pressurization of the classroom, i.e., more outside air can be introduced through the GreenWheel® ERV than is exhausted.

GreenCube® ERV (Ventilation Option "Q")

The Marvair GreenCube ERV is an enthalpy plate heat exchanger that transfers both sensible and

latent energies between outgoing and incoming air streams in a cross flow arrangement. Except for two air movers, it has no moving parts. The media is impregnated with a RC134 polymeric desiccant that exchanges water by direct vapor transfer using molecular transport without the need of condensation. The GreenCube® ERV will operate at temperatures as low as 10°F without a defrost mechanism. In addition, the desiccant is a bactericide. Two MERV 6 type filters are used on both sides of the enthalpy core. The fresh air and exhaust motors have independent speed controllers to permit each of the motors to be regulated independently.

The GreenCube® ERV is available in heat pumps with nominal cooling capacities of 36,000 thru 60,000 BTUH. All Classic heat pumps with the GreenCube® ERV are in the HVPA49/60 cabinet.

Hot Gas Reheat (HGR) Dehumidification Mode (Special Option "G")

When the HGR is in the dehumidification mode, the hot gas reheat (HGR) coil is energized. The cooled, dehumidified air exits the evaporator coil and is blown through the HGR coil. This coil is sized to the sensible capacity of the unit. The heat in the HGR coil is transferred to the air stream. The use of the HGR coil allows the indoor humidity of the classroom to be maintained at or below a certain set humidity set point without over cooling the classroom. These units can not add humidity to the classroom.

The operation of the HGR coil is controlled by a humidity controller. If the humidity rises above the set point on the controller and the temperature in the classroom is satisfied, both mechanical cooling and the HGR coil operate to temper the air and lower the humidity. If the temperature in the classroom rises above or falls below the set point of thermostat and the unit is operating in the dehumidification mode, the need for cooling or heating will override the call for dehumidification and the HGR coil is disengaged until the thermostat is satisfied. This assures the classroom temperature is maintained as first priority and humidity control is second.

The humidity controller or BAS control is required for proper operation of the HGR coil.

Economizer Operation - Cooling Cycle (Classic Heat Pump with Economizer only)

The economizer is a regulated damper system with controls. The damper regulates the circulation of outside air into the enclosure (when the outdoor air conditions are suitable) to reduce the need for mechanical cooling, save energy, and extend compressor life.

Depending upon the options selected, the damper responds to either enthalpy or dry bulb temperature of the outdoor air. On a call for cooling from a space thermostat, it operates as follows:

When the enthalpy of the outdoor air is below the set point, the outdoor air damper is proportioned open (and return air damper is proportioned closed) to maintain between 50°F and 56°F at the mixed/discharge air sensor.

When the enthalpy of the outdoor air is above the set point, the outdoor air damper closes to its minimum position. A call for cooling from the space thermostat brings on mechanical cooling.

An optional built-in adjustable minimum position potentiometer, p/n 70012, controls the amount of outdoor air admitted to meet minimum ventilation requirements.

1.4 Standard Controls- PC Board

Description of Operation

The PC board controls the operation of the indoor blower, the compressor and the reversing valve

while providing high pressure, loss of charge protection with an integral defrost function. Upon a call for mechanical cooling or heating, the controller will energize the compressor when a 24 VAC signal is applied to the “Y” terminal provided that all time delays and fault conditions are satisfied. It will energize the indoor blower when a 24 VAC signal is applied to the “G” terminal. The reversing valve will be energized when a 24 VAC signal is applied to the “O” terminal. Electric heat (EH) will be energized when a 24 VAC signal is applied to the “W2” terminal. The control will monitor the status of the loss of charge switch and the high pressure switch. If either of these inputs recognize a fault, the compressor will turn off and the anti-short cycle delay will be initiated. If any of these faults occur twice within a one hour period, the control will lock the compressor out until the power is reset manually. Note: 24 VAC power must be continuously applied to “R” and “C”.

The board will also monitor the defrost sensor. If the defrost sensor senses a temperature of 32°F while in the heat mode, it will initiate a pin selectable 30, 60, or 90 minute delay period. (Factory set at 60 minutes). If the sensor is still calling for defrost at the end of this delay period, it will de-energize the outdoor fan and energize the reversing valve through the RV terminals. The defrost cycle will terminate on time or temperature. It will have a maximum defrost run time of 10 minutes, however, if the defrost sensor registers a temperature of 50°F or higher before the 10 minute maximum run time, the defrost cycle will terminate. The EH terminals will also be energized during a defrost cycle if the EHDD (Electric Heat During Defrost) jumper is in the “Yes” position.

The board also provides the ability to vary the speed of the indoor blower motor (electronically commutated motors excepted) and to select the number of seconds the blower will run after the compressor has turned off (Post Purge). The user can select whether the compressor and electric heat operate simultaneously (the S-Circuit) and if electric heat operates during the defrost mode (EHDD). The board can control the operation of a two position motorized damper to provide fresh air for ventilation (DRO/DRC). In conjunction with an optional temperature sensor, the board will modulate the speed of the outdoor fan motor to allow cooling during low ambient temperatures.

LED's indicate power, operating status and high pressure or loss or charge lockout.

Functions

Lockout Protection

If either of the fault conditions (LPS or HPS) occurs twice within one hour, the control board will enter into and indicate the lockout mode. In the lockout mode, the compressor is turned off. If there is a call for indoor air flow “G”, the blower remains energized, the alarm output is energized and the red LED will blink to indicate which fault has occurred. When the lockout condition is cleared, the unit will reset if the thermostat is turned “Off” and back to “On” or when the power to the heat pump is reset. With the control board, the user can select either normally closed or normally open remote alarm dry contacts by moving a wire on the control board. The heat pump is factory wired to be normally open.

Delay on Break

The board has an integral three minute delay on break (anti-short cycle) timer. This timer initiates every time the compressor turns off to prevent a short cycle condition.

Loss of Charge (LPS) By-Pass Timer

The control includes a fixed, three minute Loss of Charge Switch (LPS) bypass timer. If the Loss of Charge Switch is open on initial power up or while the compressor is running, the control will ignore the fault for three minutes. If the fault still exists after three minutes, the control will de-energize the compressor, register a loss of charge fault, and initiate the three minute anti-short cycle timer.

User Selectable Settings

The control board has three potentiometers (pots) that allow the user to select settings to optimize the installation. See *Figure 1* for location of the pots.

Delay on Make

The control has a pot settable 0.03 to 10 minute delay on make timer that initiates upon initial power up only. The factory set time is three minutes.

Post Purge Potentiometer

The board includes a pot settable 10-90 second post purge timer. When the signal at the “G” terminal is removed, the indoor blower will remain energized for the amount of time selected by the pot. The pot is factory set at ninety seconds.

Indoor Blower Motor Speed Control Potentiometer

The control has a speed control potentiometer for the indoor fan blower. The user can vary the speed of the fan using this potentiometer from approximately 40% to 100% of rated air flow. Caution should be used when slowing the speed of the indoor blower; sufficient air flow is critical to the proper operation of the heat pump. Note: the indoor blower motor speed control is not functional on the HVPA and HVPSA units with electronically commutated (EC) motors.

The control board has four operational modes that can be defined by the installer. These modes are selected with jumpers. See *Figure 1* for location of the jumpers. To change the factory setting, **gently** pull the jumper and slide it onto the desired setting.

Damper Relay (Damper Relay Open-DRO / Damper Relay Closed-DRC)

The board has a two position, motorized fresh air damper (ventilation option “B”) from the “G” input when this option is selected. It is pin selectable using a jumper to select “Yes” to enable it. When “Yes” is selected, the control will energize the Damper Relay Open terminal when “G” is calling for the damper to open. When the “G” signal is not present, the control will energize the Damper Relay Closed terminal to close the damper. When “No” is selected, this feature is disabled. The factory setting for the damper relay option is “No”.

Defrost Mode

The board has an integral defrost cycle that will be initiated by the Defrost Sensor (DS). If the defrost sensor registers a temperature of 32°F while in the heat mode, it will initiate a pin selectable 30, 60, or 90 minute delay. The factory setting is 60 minutes. If the sensor is still calling for defrost at the end of this delay, it will de-energize the outdoor fan, energize the reversing valve through the RV terminals, and keep the compressor energized. The defrost cycle will terminate on time or temperature. It will have a maximum defrost run time of 10 minutes, however, if the defrost sensor registers a temperature of 50°F or higher before the 10 minute maximum run time, the defrost cycle will terminate. If “Yes” has been selected for Electric Heat During Defrost (EHDD) and “No” selected for the S-Circuit, the electric heat (EH) output will be energized during a defrost cycle to supply heat while the coil defrosts.

Electric Heat During Defrost (EHDD)

The board provides the option of running the electric heat (EH) during a defrost cycle. There are

two options for the EHDD, “Yes” and “No”. If “Yes” is selected, the board will energize the EH terminals during a defrost cycle. If “No” is selected, the EH terminals will not be energized during a defrost cycle. The factory setting for EHDD is “No”. If the S-circuit is in the “Yes” position, the EHDD function will be disabled.

S-Circuit

The S-Circuit prevents the compressor and electric heat from operating simultaneously. The S-Circuit is pin selectable using a jumper to select “Yes” to enable this feature or “No” to disable it. When “Yes” is selected, the control will not allow the compressor to run when there is a call for electric heat at the W2 input. It will turn the compressor off until the call for W2 is satisfied. The factory setting for the S-Circuit is “No”.

Test Mode

A jumper selectable test mode can be used by technicians for trouble shooting purposes. The test mode reduces the delay on make and anti-short cycle timers to ten seconds, and the LPS bypass becomes two minutes.

Internal Head Pressure Control (Requires optional coil sensor)

The control has an internal, fixed set point head pressure control designed to maintain a constant head pressure under low ambient conditions. It will monitor a coil sensor that is inserted into the condenser fan coil and modulate the speed of the fan motor accordingly to maintain a constant coil temperature in turn stabilizing the head pressure. The fixed set point that the control will maintain is 100°F. The motor will have a minimum operating speed of 20%-30% of the full speed. It will also incorporate a fixed hard start time of one second during which the condenser fan motor will turn on full speed for one second at start up.

High Pressure Switch (HPS)

The high pressure switch is mounted on the compressor liquid line. The HPS terminals are on the high pressure switch input. This input monitors the status of the high pressure switch and determines when this fault condition is present. If the HPS is open on the initial “Y” call, the control board will not allow the compressor to operate. If the HPS opens while the compressor is running, the control board will turn the compressor off, register the first HPS fault, and initiate the 3 minute anti-short cycle timer. If two HPS faults occur within a one hour period, the control will enter a HPS lockout condition and energize the alarm contacts. The RED status LED will blink once to indicate this condition. The lockout condition will only be reset by manually cycling power to the control to prevent destructive short cycling. To reset the switch, turn primary power off, then back on or turn thermostat system switch off, then back on.

The high pressure switch opens at 620 psig and closes at 420 psig.

Loss of Charge Switch (LPS)

The loss of charge switch is mounted on the compressor’s liquid line. The LPS terminals are the loss of charge switch input. This input will be used to monitor the status of the loss of charge switch and determine when a LPS fault is recognized. There is 3 minute loss of charge switch bypass timer. If the LPS is open on the initial “Y” call or while the compressor is running, the control will ignore the status of the LPS and not recognize a fault for 3 minutes. If the LPS is still open after 3 minutes,

the control will de-energize the compressor, register the first LPS fault, and initiate the 3 minute anti-short cycle timer. If two LPS faults occur within a one hour period, the control will enter a LPS lockout condition and energize the alarm contacts. The RED status LED will blink twice to indicate this condition. The lockout condition will only be reset by manually cycling power to the control. To reset the switch, turn primary power off, then back on or turn thermostat system switch off, then back on.

The loss of charge switch opens at 40 psig and closes at 60 psig.

Status LED Blink Codes

There are two LEDs on the board. The green LED is used as a power indicator. The red LED is used to indicate the two fault lockout conditions. During a HPS lockout, the red LED blinks once. During a LPS lockout, the red LED blinks twice.

COLOR TYPE STATUS DESCRIPTION

Color	Type	Status	Description
Green	Power	Constant On	24 VAC power has been applied
Green	Status	Constant On	Normal Operation
Red	Status	1 Blink	High pressure switch has opened twice
Red	Status	2 Blinks	Loss of charge switch has opened twice
Red	Status	3 Blinks	Faulty or disconnected defrost sensor

Board Inputs

R and C. The R and C terminals are the input power terminals for the control. They will accept any voltage between 19-32 VAC.

Y The “Y” terminal is the compressor input from the thermostat. Given that all time delay and fault conditions are satisfied, the control will energize the compressor contactor through the “CC” terminals when there is a 24 VAC signal present at the “Y” terminal.

W2 The “W2” terminal is the electric heat input from the thermostat. When the control receives a call for “W2” from the thermostat, it will energize the EH terminal. When the S-Circuit is selected by placing the jumper in the Yes position, the control will not allow the compressor to run simultaneously with electric heat. The default setting for the S-Circuit is “No”. If “Yes” is selected for the S-circuit, the EH output will not energize during defrost.

O The “O” terminal is the reversing valve input from the thermostat. When there is a 24 VAC signal present at the “O” terminal, the control will energize the reversing valve through the “RV” terminals. The control will also energize the “RV” terminals in heat mode during a defrost cycle.

G The “G” terminal is the indoor blower input from the thermostat. When there is a 24 VAC signal present at the “G” terminal, the control will energize the indoor blower. When the signal at the “G” terminal is removed, the fan will remain energized for the pot settable 10-90 second post purge period. When the damper relay option is selected by placing the jumper in the “Yes” position, the control will energize the DRO terminal with every “G” call to open the damper. When the “G” call is not present, the control will energize the DRC terminal to close the damper. The default setting for the damper relay option is “No”.

HPS High Pressure switch terminals are the high pressure switch input.

LPS Loss of Charge switch terminals are the loss of charge switch input.

DS The DS terminals are the defrost sensor input.

CS The CS terminals are the coil sensor (optional) input. This input will monitor the condenser coil temperature to allow the head pressure control to modulate the speed of the fan and maintain a constant head pressure.

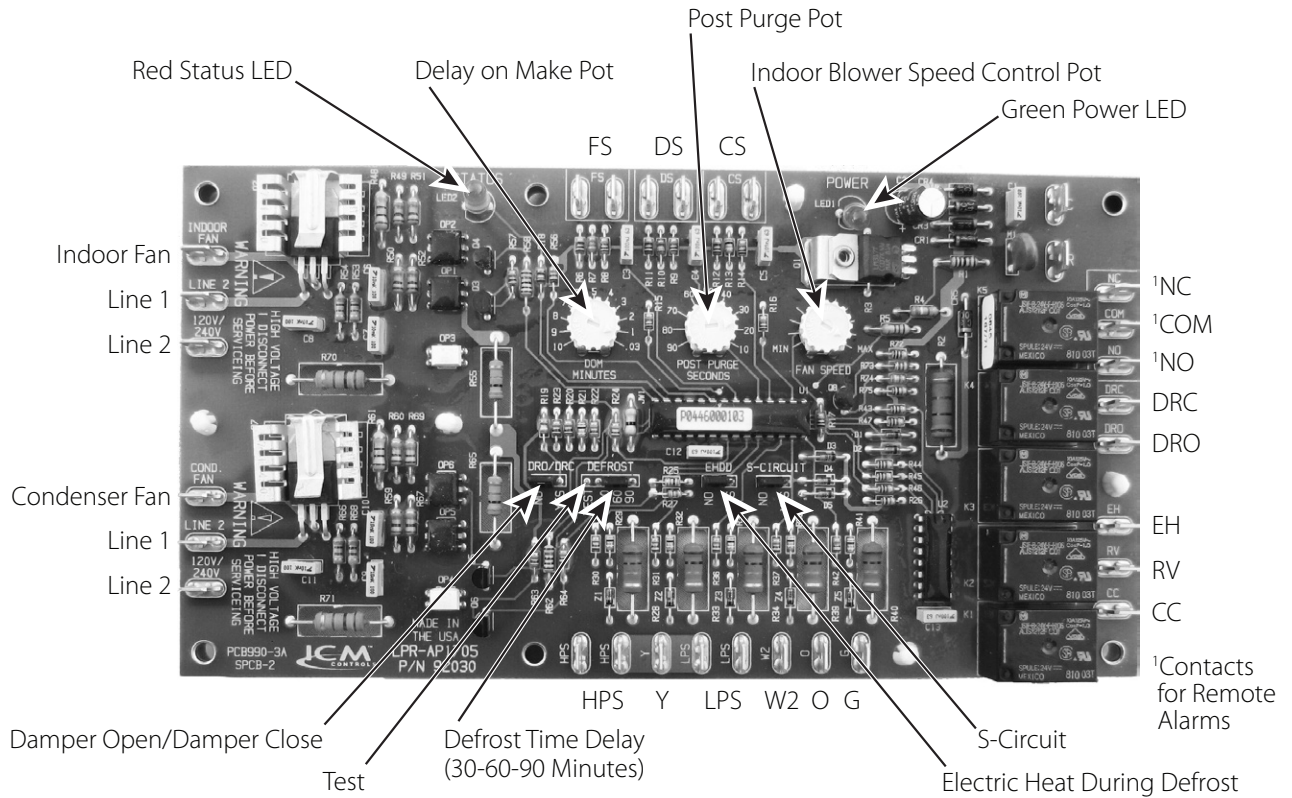

Figure 1 - PC Control Board

1.5 Options

Low Ambient Control

The low ambient control permits mechanical cooling when outdoor ambient temperatures are low. The control uses a reverse-acting high pressure switch to cycle the condenser fan motor according to liquid refrigerant pressure conditions. Switch closure and fan operation occurs when the pressure reaches 400 PSIG. The switch opens again when the refrigerant pressure falls to 245 PSIG. Therefore, the outdoor fan always starts after the compressor, **and it will cycle frequently during normal operation at low outdoor conditions.**

Hard Start Kit

Used on single phase equipment to give the compressor higher starting torque under low voltage conditions. Field installed only. (Not generally recommended for use on scroll compressor.)

Adjustable Outdoor Thermostat

Will not allow electric resistance heat to be energized unless the outdoor temperature is below the desired set point. Field or factory installed. Available on all Classic units. P/N 93934

Single Point Feed

When multiple internal disconnects are used, single point feed permits only one field power supply to heat pump. Field installed only. Available on all Classic units.

Energy Management System (EMS)

Relay to control the heat pump. Available in 24, 120 or 240 VAC. Field or factory installed.

Electric Reheat for Dehumidification

Control provides simultaneous operation of compressor when in cooling mode and the electric elements to provide dehumidification without over cooling the room. The electric element (kW) must be properly sized for each model for proper operation. Factory installed. Available on all Classic units. Consult factory for details.

Hot Gas Reheat (HGR)

Marvair® heat pumps equipped with the Hot Gas Reheat (HGR) allow the indoor humidity of the controlled environment to be maintained at or below a certain humidity set point. These units do not have the ability to add humidity to the classroom.

Dehumidification is achieved by operating mechanical cooling in conjunction with a hot gas reheat coil. The coil is sized approximately to the sensible capacity of the total tonnage of the machine.

Speed Control for GreenWheel® ERV Exhaust Blower

For separate control of the exhaust blower. When used, the standard speed controller operates the intake blower and the optional second controller the exhaust blower. Individual blower control allows positive pressurization of the classroom. Can be factory or field installed.

1.6 Economizer Operation and Components

Damper Actuator

The damper actuator is a motor that modulates the position of the damper blade. It is controlled by the enthalpy controller and powered by the 24 VAC control transformer. It is capable of driving a full 90 degrees within 90 seconds. The assembly has a spring return to close the damper during power outage.

Controls

The economizer is controlled by an enthalpy sensor or optional dry bulb sensor.

Economizer Changeover Control

The enthalpy sensor responds to the total heat content of the outdoor air to provide changeover to outside air for free cooling. The change point is adjustable from 63°F @ 50% RH (full clockwise) to 73°F @ 50% RH (full counterclockwise). Refer to Figure 3.

Once the enthalpy sensor has selected outside air, the mixed air sensor will limit the air temperature delivered to the space by modulating the damper blade to "mix in" a quantity of inside air to provide a constant 50° to 63°F. (Adjustable minimum potentiometer is optional.)

The sensor modulates the position of the outside air damper in response to input from the enthalpy and mixed air sensors. The controller is designed to maintain the supply air temperature between 50° to 56°F by mixing warm indoor air with cooler outdoor air.

On a call for cooling from the wall-mounted thermostat, if outdoor conditions are suitable, the sensor will open the damper and admit outside air (i.e., economizer cooling). If the outdoor ambient is too hot or humid, the sensor will place the actuator in the closed or minimum open position and activate mechanical cooling. The compressor is locked out during the economizer cooling mode.

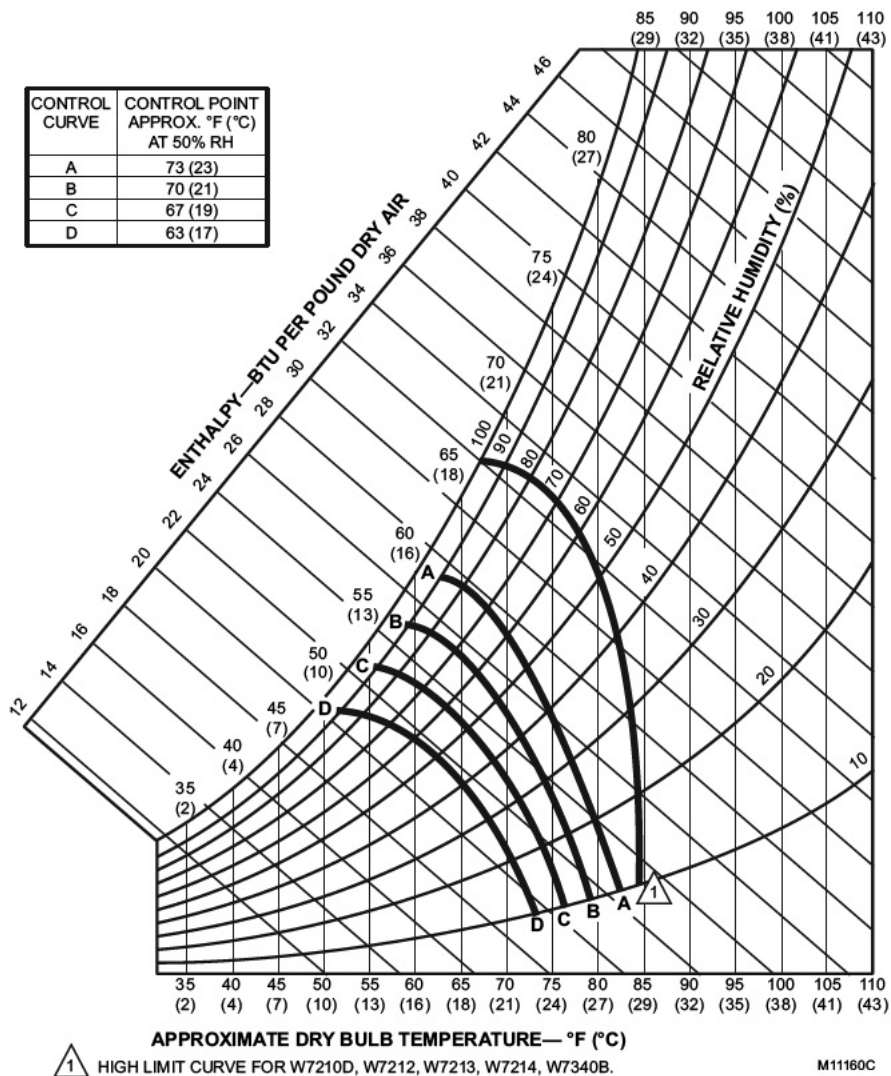

Figure 2 - Enthalpy Sensor Temperature Control Points

Mixed Air Sensor

The mixed air sensor is a thermistor mounted on a bracket adjacent to the right side of the blower assembly. The thermistor senses the air temperature entering the structure, and provides a signal to the economizer controller for modulating the position of the damper. Nominal resistance of the sensor at 77°F is 3000 ohms.

Installation

WARNING

Failure to observe and follow Warnings and Cautions and these Instructions could result in death, bodily injury or property damage. Read this manual and follow its instructions and adhere to all Cautions and Warnings in the manual and on the Marvair unit.

2.1 Equipment Inspection

Concealed Damage

Inspect all cartons and packages upon receipt for damage in transit. Remove cartons and check for concealed damage. Important: Keep the unit upright at all times. Remove access panels and examine component parts. (Note: The bottom bracket is stored in the condenser air compartment. Remove them before replacing the side screen). Inspect refrigerant circuit for fractures or breaks. The presence of refrigerant oil usually indicates a rupture. If damage is apparent, immediately file a claim with the freight carrier.

Units that have been turned on their sides or tops may have concealed damage to compressor motor mounts, to the oil system or to other components. If the unit is not upright, immediately file a claim for concealed damages and follow these steps:

1. Set unit upright and allow to stand for 24 hours with primary power turned on.
2. Attempt to start the compressor after 24 hours.
3. If the compressor will not start, makes excessive noise, or will not operate, return the unit to the freight carrier.

General

1. Inspect unit for completeness. Check for missing parts (e.g. hardware). Refer to the installation kit information in section 2.3.
2. Remove access panels and check for loose wires. Tighten screw connections.
3. Complete and mail the warranty registration card.

2.2 Installation Requirements

You must consider all of the following when choosing the installation site:

1. **Noise.** Install the unit so that the least amount of noise will be transmitted to inhabited spaces.
2. **Condensate Drainage.** Condensate produced during operation must be discharged to a suitable drain.
3. **Defrost Drainage.** Ice build up sometime occurs during the heating cycle while in heat pump operation. The automatic reversal (defrost control) of the heat pump cycle causes the ice to melt so that the heat pump may operate efficiently. Please keep this in mind while locating unit.
4. **Placement.**
 - A) Place the unit in a shaded area, if possible.
 - B) Install it above ground for protection against flooding.

C) The unit exhausts air. Be sure that the airflow is not impeded by shrubbery or other obstructions.

D) When installing multiple units, please note the recommended clearances noted in Table 4.

5. **Airflow Requirements:**

Note the minimum CFM requirements (section 2.4). Keep duct lengths as short as possible. Do not obstruct airflow through the unit.

Applications using duct work should be designed and installed in accordance with all applicable safety codes and standards. Marvair® strongly recommends referring to the current edition of the National Fire Protection Association Standards 90A and 90B before designing and installing duct work. The duct system must be engineered to insure sufficient air flow through the unit to prevent over-heating of the heater element. This includes proper supply duct sizing, sufficient quantity of supply registers, and adequate return and filter areas. Duct work must be of correct material and must be properly insulated. Duct work must be constructed of galvanized steel with a minimum thickness of .019". Duct work must be firmly attached, secured, and sealed to prevent air leakage. See section 2.4 for additional duct work requirements.

6. **Clearances:**

When facing the unit from the outside, the minimum clearances are found below. Note the minimum clearances required for proper operation and service (Tables 4a & 4b below).

MODEL	Min. Clearance From the Front	Min. Clearance Around Sides (Single Unit)	Min. Clearance Between Sides (Two Units)	Min. Space Above Unit
24	42 inches	30 inches	18 inches	24 inches
30/36	42 inches	30 inches	18 inches	24 inches
42/48/60	42 inches	30 inches	30 inches	24 inches

Table 4a - AVPA Minimum Clearances

MODEL	Min. Clearance From the Front	Min. Clearance Around Sides (Single Unit)	Min. Clearance Between Sides (Two Units)	Min. Space Above Unit
24	42 inches	30 inches	18 inches	24 inches
30/36	42 inches	30 inches	30 inches	24 inches
42/49/60	42 inches	30 inches	30 inches	12 inches

Table 4b - HVPA Minimum Clearances

7. **Codes:**

Make sure your installation conforms to all applicable electrical, plumbing, building, and municipal codes. Some codes may limit installation to single story structures.

8. Electrical Supply:

The power supply must have the appropriate voltage, phase, and ampacity for the model selected. Voltage must be maintained above minimum specified values listed below. Refer to the unit data plate for ampacity requirements.

Electrical Rating Designations*	A	C	D
Nominal Voltage	208/230	208/230	460
Phase	1	3	3
Minimum Voltage	197	197	414
Maximum Voltage	253	253	506
* Letters refer to model number code designations. Refer to page 5.			

Table 5 - Voltage Limitations

2.3 Installation Materials

Installation Kits

The Classic Heat Pumps have built-in mounting flanges that function as side brackets. All models require and are shipped with a bottom mounting bracket. On units with the "N" ventilation option, there is a fresh air hood factory installed behind the lower front panel.

Standard Kit Components

1. One 12 Ga. "L"-shaped bottom bracket

Accessories:

The package may include other factory-supplied items (optional) listed on this and the following page:

PART # DESCRIPTION

- 50107 Digital thermostat. 2 stage heat, 2 stage cool. 7 day programmable. Fan switch: Auto & On. Auto-change over. Status LED's. Backlit display. Programmable fan. Non-volatile program memory. Title 24 compliant - no batteries needed.
- 50252 Digital thermostat. 2 stage heat, 2 stage cool. Non-programmable. Fan switch: Auto & On. Manual or auto changeover system switch: Cool-Off-Heat-Emergency Heat. Status LED's. °F or °C. Permanent retention of settings on power loss. Field adjustable temperature calibration. Adjustable maximum setpoint for heating and minimum adjustable set points for cooling. Adjustable temperature differential. Keypad lockout.
- 50248 Digital, 7 day, 2 occupied & 2 unoccupied periods for each day of the week programmable thermostat. Three stage heat/Three stage cool. Manual or auto changeover. Fan: Auto & On. Ten year retention of programming settings and 48 hour clock and day settings on power loss. Adjustable max. setpoint for heating and min. adjustable setpoints for cooling. Adjustable temperature differential. Keypad lockout. Status LED. °F or °C selectable. Optional remote sensors for outdoor air, supply air and humidity. Title 24 compliant.

PART # DESCRIPTION

50254 Humidity Controller is a wall mounted remote control used when the reheat dehumidification option is chosen on the Heat Pump. The humidity controller controls the heat pump system when cooling or heating requirements are satisfied, and the need exists to dehumidify the conditioned space. When cooling or heating is required the thermostat controls the heat pump system operation.

50092 Thermostat Guard. For use with the 50107 and the 50252.

Supply Grilles

80674 20" x 8" Adjustable, Aluminum, Double Deflection Supply Grille for AVPA 24

80675 28" x 8" Adjustable, Aluminum, Double Deflection Supply Grille for AVPA 30-36 and HVPA 24

80676 30" x 10" Adjustable, Aluminum, Double Deflection Supply Grille for AVPA 42-48-60 and HVPA 30-36-42-49-60

Return Grilles

80677 20" x 12" Aluminum Return Grille for AVPA 24

80678 28" x 14" Aluminum Return Grille for AVPA 30-36 and HVPA 24

80679 30" x 16" Aluminum Return Grille for AVPA 42-48-60 and HVPA 30-36-42-49-60

Return Air Filter Grille

80672 28" x 14" Return Air Filter Grille. Required for use with the AVPA24/30/36 & HVPA24 units with the Greenwheel ERV

Additional Items Needed:

Additional hardware and miscellaneous supplies (not furnished by Marvair®) are needed for installation. For example, the list below contains approximate quantities of items typically needed for mounting a unit on a wood frame wall structure with standard full length mounting bracket or flanges. Concrete or fiberglass structures have different requirements.

- (10) **3/8" mounting bolts** or lag screws for side brackets and anchors, if required for side brackets.
- (20) **3/8" washers**
- (10) **3/8" hex nuts**
- (6) **3/8" x 2-1/2" lag screws** for bottom bracket
 - **Silicone Sealer** to seal around cracks and openings
 - **7-conductor low voltage multi-colored wire cable** (i.e. thermostat wire)
 - **Appropriate electrical supplies** such as **conduit, electrical boxes, fittings, wire connectors,** etc.
 - **High voltage wire**, sized to handle the MCA (minimum circuit ampacity) listed on the data plate.
 - **Over-Current Protection Device** sized in accordance with the MFS (maximum fuse size) listed on the unit data plate.

Duct materials usually are also needed in addition to the mounting hardware. To save time, design the duct work before mounting the unit.

2.4 Porting and Duct Work

WARNING **FIRE HAZARD**

Improper adjustment, alteration, service, maintenance or installation could cause serious injury, death and/or property damage.

Installation or repairs made by unqualified persons could result in hazards to you and others. Installation MUST conform with local codes or, in the absence of local codes, with codes of all governmental authorities have jurisdiction.

The information contained in this manual is intended for use by a qualified service agency that is experienced in such work, is familiar with all precautions and safety procedures required in such work, and is equipped with the proper tools and test instruments.

General Information

Note: The following instructions are for general guidance only. Due to the wide variety of installation possibilities, specific instructions will not be given. When in doubt, follow standard and accepted installation practices, or contact Marvair® for additional assistance.

Wall Openings

Measure the dimensions of the supply and return openings on the Classic heat pump.

WARNING

Cut the supply opening in the exterior wall for the supply and return. IMPORTANT: All units must have one inch clearance on all four sides of the supply outlet duct flange on the unit. The one inch clearance must extend on all sides of the supply duct for the first three feet from the unit. The duct must be constructed of galvanized steel with a minimum thickness of .019".

Minimum Airflow Requirements

WARNING

The duct system must be engineered to assure sufficient air flow through the Classic Heat Pump, even under adverse conditions such as dirty filters, etc. Proper engineering will insure longevity and maximum performance from the Classic Heat Pump.

Ducting

Extensions should be cut flush with the inside wall for applications without duct work.

Applications using duct work should be designed and installed in accordance with all applicable safety codes and standards. Marvair® strongly recommends referring to the current edition of the National Fire Protection Association Standards 90A and 90B before designing and installing duct work. The duct system must be engineered to insure sufficient air flow through the unit to prevent over-heating of the heater element. This includes proper supply duct sizing, sufficient quantity of supply registers, adequate return and filter area. Ductwork must be of correct material and must be properly insulated. Ductwork must be constructed of galvanized steel with a minimum thickness of .019". Ductwork must be firmly attached, secured and sealed to prevent air leakage. Do not use duct liner on inside of supply duct within four feet of the unit.

Galvanized metal duct extensions should be used to simplify connections to duct work and grilles. Use fabric boots to prevent the transmission of vibration through the duct system. The fabric must be U.L. rated (UL-181) to a minimum of 197°F.

2.5 Fresh Air Hood

The fresh air hood is located on the inside, behind the slots on the bottom front panel. To access the hood, remove the screws that hold the front panel. The air flow can be adjusted from no (0%) fresh air to approximately 15% of rated air flow of fresh air, in 5% increments. The hood is shipped from the factory in the closed position (no fresh air). To provide fresh air, remove the two screws on either side of the hood and reposition as desired.

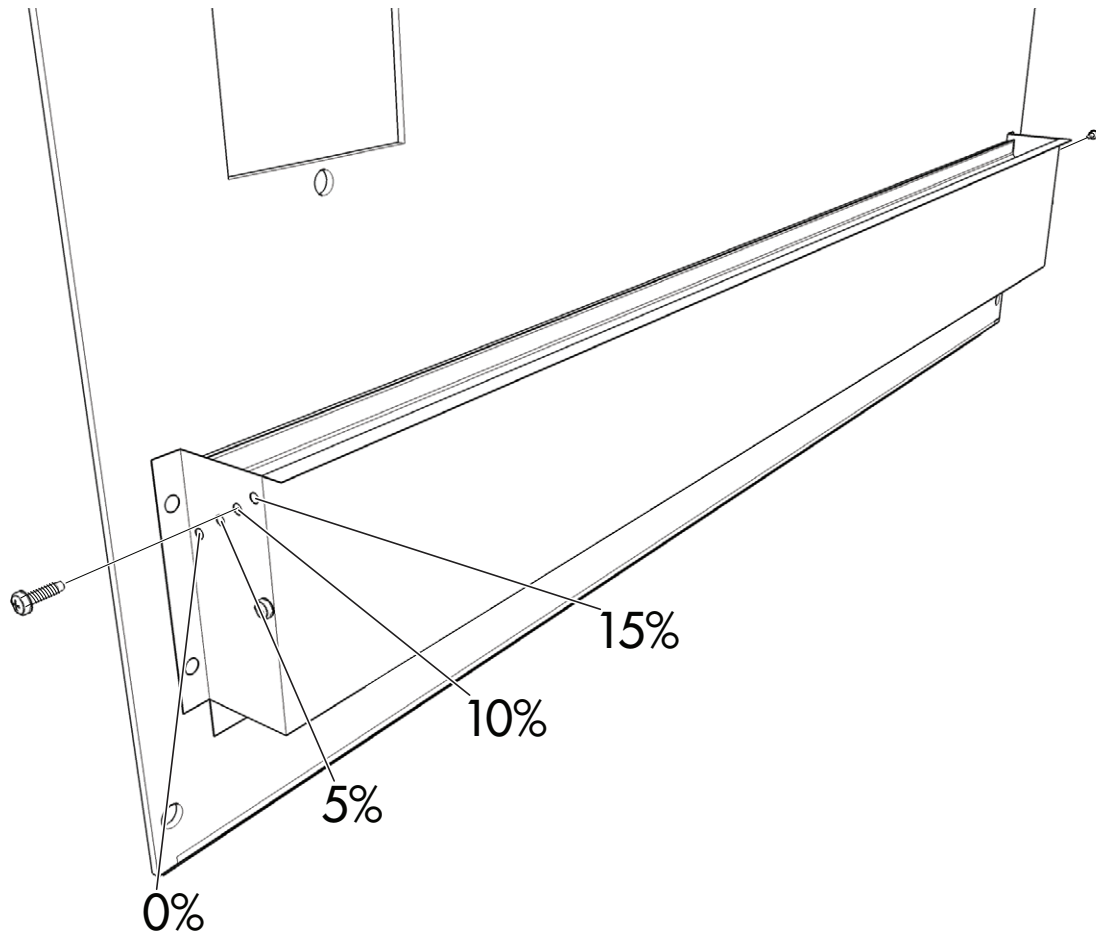
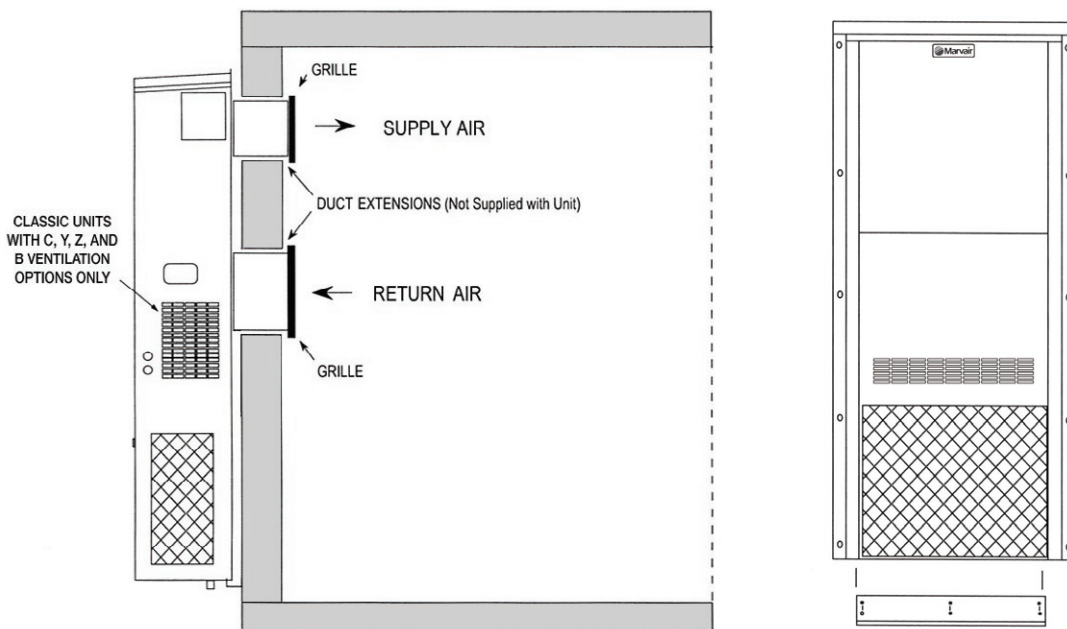

Figure 3 - Fresh Air Hood Damper Adjustment

2.6 Bottom Bracket Installation

1. Remove and discard the 4 x 4 shipping boards attached to the base of the unit.
2. The Classic models have built-in mounting flanges. See Figure 6.
3. Refer to Figure 6. Attach the bottom support bracket to the wall using appropriate 3/8" diameter hardware.

For example, on wooden structures, use 3/8 x 2-1/2 inch all-thread lag screws. The screws must penetrate the center of the wall stud. Drill a pilot hole in the stud to prevent it from splitting.



For units with electric heat, a 1" clearance around the duct extensions is required. The duct extensions must be made of galvanized steel with a minimum thickness of .019" as per the NFPA standards 90A & 90B.

Figure 4 - Classic Heat Pump Wall Mounting Detail

2.7 Mounting the Unit

1. For wiring into the back of unit, locate the lower of the two knock-outs on the wall side of the Classic Heat Pump. Drill a one inch hole in the building wall to match this opening. Allow sufficient clearance to run 3/4" conduit through the hole and to the unit.
2. Apply a bead of silicone sealer on the wall side of the mounting brackets on the Classic Heat Pump. Circle the mounting holes with the silicone bead.
3. **Using an appropriate and safe lifting device**, set the Classic Heat Pump on the bottom support bracket mounted on the wall. You must stabilize the unit on the bracket with the lifting device or by some other means - the bracket alone is not sufficient.
4. Make sure that the duct flanges are properly aligned with the wall opening. Adjust as necessary.
5. Note the holes in each side bracket. Using the holes for guides, drill holes through the wall with a 3/8 inch drill bit. Insert the 3/8" bolts or lag screws through the brackets. Tighten the bolts to secure the unit.
6. Apply a bead of silicone where the top flange and side brackets contact to the structure wall.
7. Fasten the top flange to the wall using #10 x 1/2 inch sheet metal screws.
8. On the inside of the structure, wall sleeves must be installed in the supply and return air openings. The sleeves should be trimmed to fit flush with the inside wall. For units with electric heat, a one inch clearance is required around the duct extensions. The duct extensions must be constructed of galvanized steel with a minimum thickness of .019" as per the NFPA standards 90A & 90B.

9. Check the fit of each sleeve to its mating flange for possible air leaks. Apply silicone sealer to close any gaps. Install the air return and supply grilles.



10. To minimize sound transmission, a latex based, insulating foam seal may be applied between the duct extensions and the frame for the wall openings. NOTE: DO NOT USE THE FOAM ON ANY UNITS WITH ELECTRIC RESISTANT HEATERS.

2.8 Electrical Connections

WARNING - ELECTRICAL SHOCK HAZARD

Failure to follow safety warnings exactly could result in serious injury, death, and/or property damage.

Turn off electrical power at fuse box or service panel **BEFORE** making any electrical connections and ensure a proper ground connection is made before connecting line voltage.

All electrical work must meet the requirements of local codes and ordinances. Work should be done only by qualified persons.

CAUTION

The Classic Heat Pump may incorporate an internal crankcase heater for compressor protection. **The crankcase heater must be energized for at least 24 hours prior to starting the compressor.**

High Voltage Wiring

The power supply should have the proper voltage, phase, and ampacity for the selected model.

1. Refer to the electrical data on the data sticker on the unit for field wiring requirements of the unit. Size the incoming power supply lines and the fuse(s) or HACR breaker(s) according to requirements described in the National Electric Code. Run the power conductors through the knockouts on the side or back of the unit. Use appropriate conduit and strain reliefs.

CAUTION

Note: Power supply service must be within allowable range (+10% - 5%) of rated voltage stamped on the unit rating plate. To operate nominal 230/208V unit at 208V, change the transformer line tap from 240V to 208V following the instruction on wiring label in unit.

2. Connect the wires to the input side of the internal breaker (L1 & L2 for single-phase units; L1, L2, & L3 for three phase models).

CAUTION

CAUTION! This system contains components that require phasing for correct rotation. Failure to observe rotation and correct on start-up will cause damage not covered by the Marvair® Warranty.

3. Scroll compressors, like several other types of compressors, will only compress in one rotational direction. The direction of rotation is not an issue with single-phase compressors since they will always start and run in the proper direction. However, three phase compressors will rotate in either direction depending upon phasing of power. Since there is a 50-50 chance of connecting power in such a way as to cause rotation in the reverse direction, it is imperative to confirm that the compressor is rotating in the proper direction at the initial field start-up of the system. Verification of proper rotation is made by observing that the suction pressure drops and the discharge pressure rises when the compressor is energized. An alternate method of verification for self contained system with small critical refrigerant charges, where the installation of gauges may be objectionable, can be made by monitoring the temperature of the refrigerant lines at the compressor. The temperature should rise on the discharge line while the suction line temperature decreases. Reverse rotation also results in a substantially reduced current draw when compared to tabulated values.

There is no negative impact on durability caused by operating three phase compressors in the reversed direction for a short duration of time, usually defined as less than one hour. However, after several minutes of operation the compressor's internal protector will trip. The compressor will then cycle on the protector until the phasing is corrected. Reverse operation for longer than one hour may have a negative impact on the bearings.

To change the rotation, turn off power to the unit and reverse L1 & L2 at the disconnect.

4. Install the ground wire on the ground lug.
5. Units designed to operate on 460v. have a step down transformer for 230v. motors.

Low Voltage Wiring

1. Pull the low voltage wiring from the Classic Heat Pump to the thermostat / sub-base assembly. Use 18 gauge, with at least 7-conductors, Class 2 thermostat wire.
2. Mount the sub-base on a level plane. Connect the thermostat wire to the unit terminal board and the thermostat as shown in Figure 7.
3. If applicable, attach the thermostat assembly to the sub-base. Check the stage two heat anticipator setting. For units with electric heat and thermostats with an adjustable heat anticipator, energize the electric heat and measure the current on the lead attached to the W2 terminal. Adjust/set the heat anticipator per the instructions provided with the thermostat.

Terminals 8 & 10 on the Classic with economizer can be connected to a normally closed smoke alarm or fire stat to cause equipment shutdown when the circuit is opened. (Remove factory jumper).

THE INTERNAL TRANSFORMER IS NOT DESIGNED TO POWER OTHER EXTERNAL DEVICES.

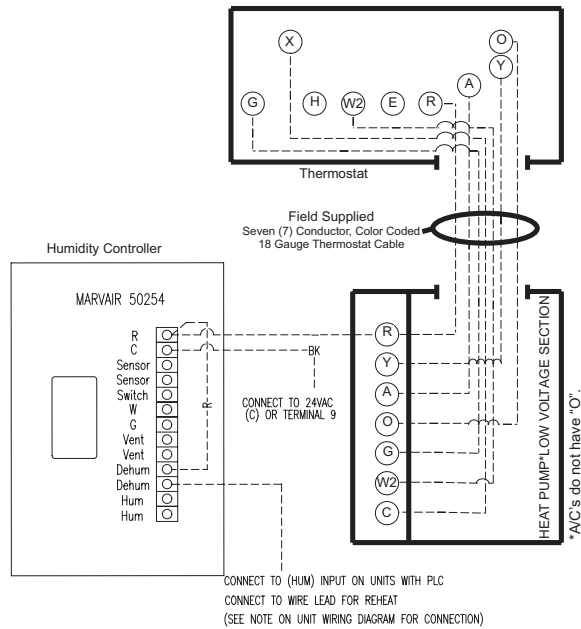
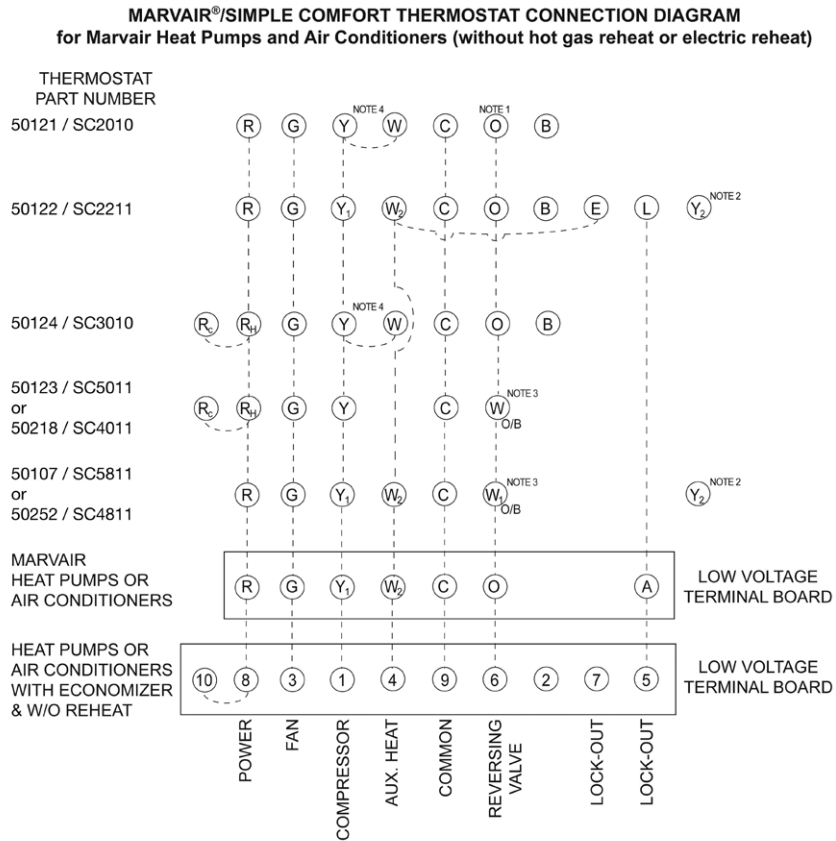

Figure 5a - Humidity Control Wiring Detail - Heat Pumps



- NOTES:
1. Reversing valve on heat pumps only.
 2. For units with 2-stage compressors, connect lead from the compressor monitor and diagnostic module, e.g., Copeland's Comfort Alert, to Y₂.
 3. For air conditioners with strip heat, connect W/O/B to terminal W or 4.
 4. Jumper for heat pump only, omit with air conditioners.
- A. Terminals 5 & 7 are normally open dry contacts and close to indicate lockout.
 B. Terminals 6 & 7 are normally closed dry contacts and open to indicate lockout.
 C. If the thermostat has RC & RH terminals, install a jumper wire between RC & RH.
 D. IMPORTANT. The instructions are generic wiring instructions and may not be applicable for air conditioners with various options. Always refer to the wiring diagram in the air conditioner for the proper method to wire your unit.

Figure 5b - Thermostat Connection Diagram

Important: If your unit has a crankcase heater be sure that the crankcase heater has been energized for at least 24 hours prior to start-up of the unit. Double check all electrical connections before applying power. Various thermostats can be used to control the heat pump. The thermostat may have a fan switch with an Automatic and On positions, a system switch with Heat, Cool, and Off positions, and an emergency heat position with lights. The spec sheets have detailed description of the various Marvair® thermostats. Since other thermostats or remote control systems may be used, the following procedures should be viewed as guidelines for standard thermostats with system and fan switches.

3.1 Check-out of Cooling Cycle

Procedure:

Classic Heat Pump

1. Set the fan switch to "Auto" and the system switch to "Off".
2. Move the cooling set point temperature on the wall thermostat to a point higher than the room temperature. Move the heating set point temperature to a temperature that is lower than the room temperature.
3. Set the thermostats system switch to "Cool" or "Auto" position. Nothing should operate at this time.
4. Set the time delay in the control box to three minutes. Note that time delay is an option on some Classic units and may not be on your heat pump.
5. Remove the cover plate from the thermostat. Slowly lower the thermostat cooling set point temperature. Once the indoor fan turns on, allow approximately three minutes for the compressor and outdoor fan to start.

For units equipped with the low ambient control, note that the outdoor fan may not come on immediately, because it is cycled by refrigerant pressures. Some units have a time delay module which prevents the compressor from restarting immediately after interruption of power. See section 1.5 for details on the operation of the low ambient control and the time delay.

If the unit fails to operate, refer to the troubleshooting information in Chapter 4.

Classic Heat Pump with Economizer

1. Set the fan switch to "Auto" and the system switch to "Off".
2. Set the cooling set point temperature on the wall thermostat to a point higher than the room temperature. Set the heating set point temperature to a temperature that is lower than room temperature.
3. Set the thermostat system switch in the "Auto" or "Cool" position. Nothing should operate at this time.
4. Set the time delay in the **Classic Heat Pump with Economizer** control box to 3 minutes. Check the enthalpy changeover setting of the H205A or dry bulb sensor, and reset it if needed. See section 1.7.
5. Slowly lower the thermostat's cooling set point temperature. The indoor fan should operate.

Once the indoor fan comes on, allow approximately three minutes for the compressor to start. Note that the outdoor fan may not come on immediately because it is cycled by refrigerant pressures

Note: To check the system operation under different ambient conditions, the air temperature and enthalpy sensors must be "tricked". When outdoor ambient conditions are higher than the control setting, a component aerosol cooler may be sprayed directly into the enthalpy sensor to simulate low enthalpy conditions, causing the economizer damper to open.

Alternately, when outdoor conditions are lower than the set point, a source of heat such as a hair dryer can be directed on the air temperature sensor to simulate warmer conditions, which will bring on mechanical cooling and start the compressor.

If the unit fails to operate, refer to the troubleshooting information in Chapter 4.

3.2 Check-Out of Heating Cycle

Procedure:

1. Place the thermostat system switch to "Auto" or "Heat" and the fan to "Auto".
2. Raise the heating set point temperature to a setting which is higher than the room temperature. The fan and compressor should cycle on after time delay (standard on Classic heat pump with economizer and all HVP models, option on all other Classic units) has cycled.
3. Move the system switch to the "Off" position. All functions should stop.

The Blower Timed Delay Relay (BTR) keeps the blower running for 90 seconds after the unit shuts off.

Note: The damper blade should remain closed during the heating cycle (unless the minimum position potentiometer has been set for constant ventilation).

3.3 Discharge Air Temperature Adjustment of Modulating Hot Gas Reheat (HGR) Valve

Units with Hot Gas Reheat may use a valve, a PC board and temperature sensor to maintain a constant discharge temperature during reheat operation. The discharge air temperature can be adjusted by the use of a potentiometer located on the PC board. The board is located in the control box of the unit. A Digital VOM is required to adjust the potentiometer.

WARNING - ELECTRICAL SHOCK HAZARD

The setting of the discharge air temperature requires that power be applied to the unit and the unit operating. Use extreme caution when working in the control box.

1. Make sure the two sensor wires are connected to the TEMP SENSOR terminals on the board. See Figure 8.

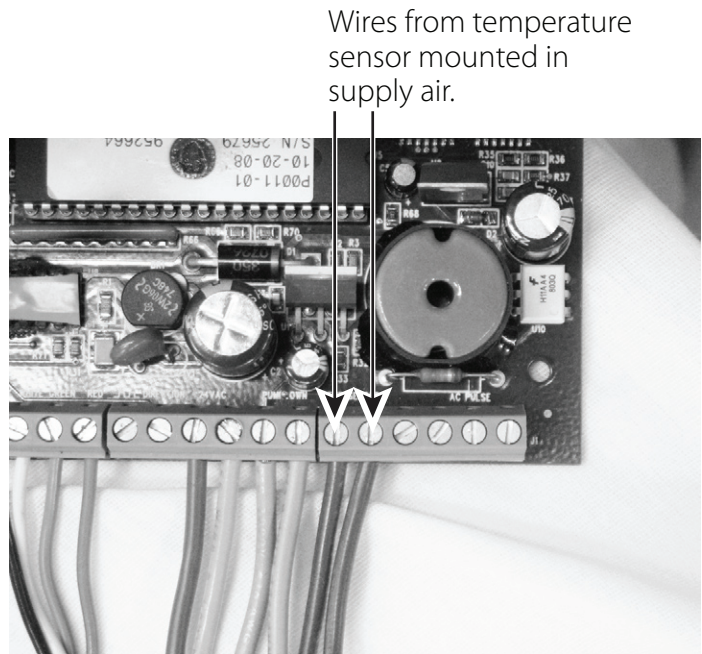

Figure 6 - Temperature Sensor Wires

2. Turn the unit on and the Hot Gas Reheat is operating.
3. Set the digital VOM for DC milliamp voltage. The milliamp voltage shown on the meter's display corresponds to the desired air temperature (°F). Insert the probes of the meter into the negative (black) and positive (red) set point test terminals on the board. Carefully, and in small increments, turn the blue knob on the potentiometer until the volt meter displays the desired milliamp voltage (temperature). Marvair recommends 70°F and no lower than 68°F and no higher than 78°F. Allow the refrigerant system to stabilize for at least five minutes and adjust the temperature as desired.

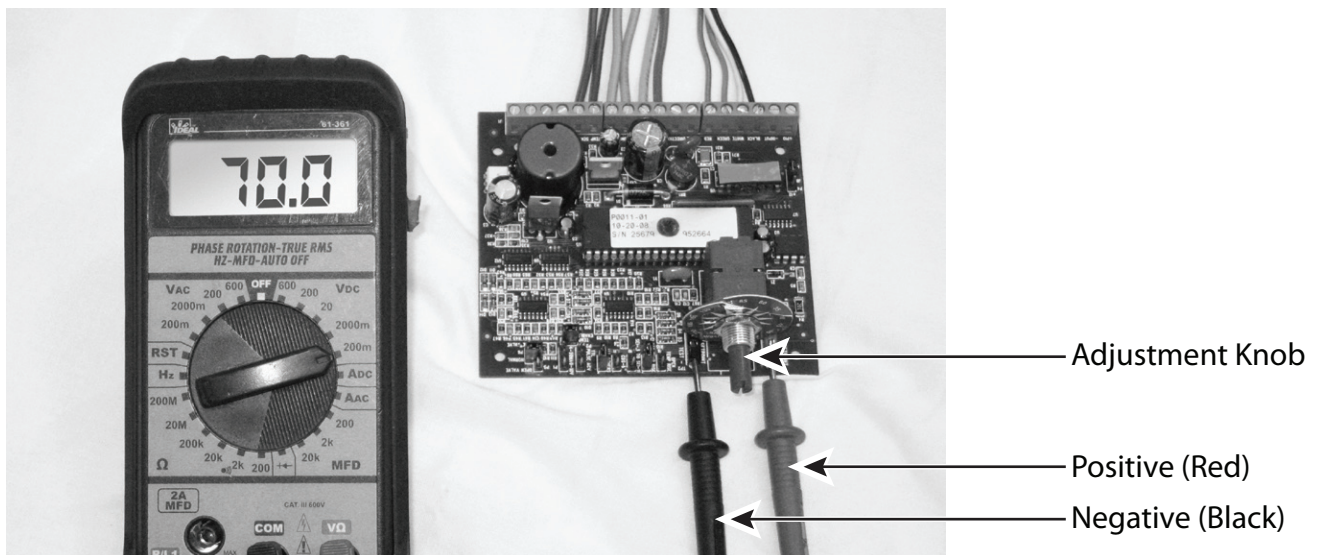

Figure 7 - Desired Temperature Set Point

3.4 Ventilation System Set-Up:

Manual Fresh Air System (Configuration N). This is the standard ventilation system in the Classic heat pump. Fresh air ventilation by means of a damper can provide up to 15% of rated air flow of outside air. The damper has four positions corresponding to 0, 5, 10 and 15% of rated air flow of outside air.

The damper only opens when the indoor fan is operating. Position the screw on the side of the damper hood for the desired air flow.

Manual Damper - 0 to 450 cfm of Outside Air, No Pressure Relief (Configuration Y). The amount of fresh air is determined by the position of the collar on the rod (*Figure 3*). To determine the desired quantity of fresh air:

- a. With the indoor blower on, measure the quantity of supply air being discharged into the room with a balometer.
- b. Now measure the quantity of the return air from the room. Subtract the return air from the supply air. The difference is the amount of fresh air.
- c. Loosen the set screw that holds the collar onto the rod connected to the damper. Move the collar and tighten the set screw.

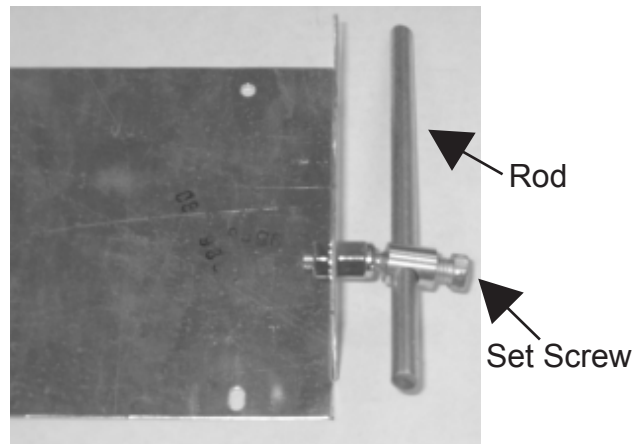

Figure 8 - Damper Adjustment

- d. Repeat steps a, b and c until the desired amount of fresh air is being introduced into the room.

Important Note: Since Configuration Y does not have internal pressure relief, the fresh air must have a passage to the outside. If a passage is not available, the desired quantity of fresh air cannot be introduced into the room.

Motorized Damper - 0 to 450 cfm of Outside Air and Pressure Relief (Configuration B) and the Manual Damper with Pressure Relief (Configuration Z). The settings of the damper require a balometer and a thermometer for measuring internal and external temperatures.

- a. Measure the total supply air with a balometer. If the supply air is controlled by a manual fan speed controller, make certain that the air flow is in accordance with Table 1, Air Flow (CFM)

at Various Static Pressures. This CFM is referred to as "C" in the illustration and equation below.

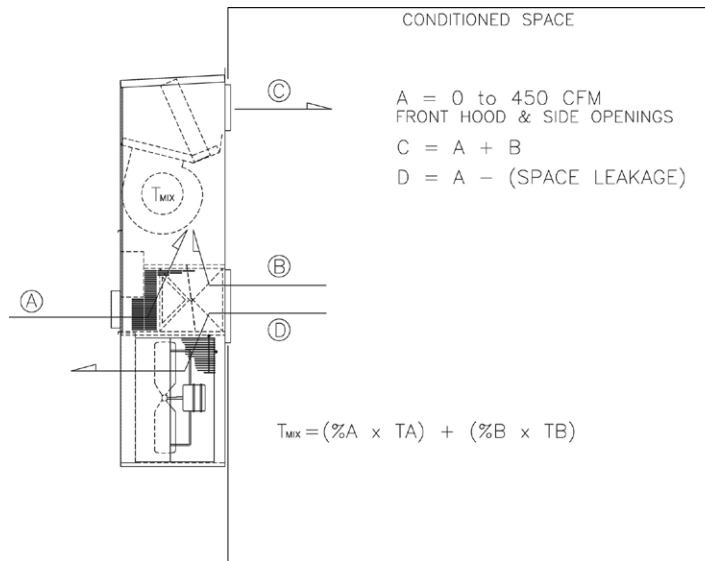

Figure 9 - Damper Air Path

- b. "A" is the quantity of outside air expressed as a percentage of "C". For example, if the supply air is 1,220 CFM and 300 CFM of outside air is required, "A" is 25% (300 CFM/1,220 CFM).

Measure the temperature of the outside air.

Multiply the temperature by "A".

- c. "B" is the quantity of return air expressed as a percentage of "C". "A" and "B" must equal 100%.

Measure the temperature of the indoor return air.

Multiply the temperature of the indoor air by "B".

- d. Calculate what the Tmix should be with the desired quantity of outside air.

Measure the actual temperature of Tmix at the inlet to the supply air blower or at the inlet of the supply air blower.

Adjust the damper blade until the measured value of the Tmix equals the calculated or desired value of Tmix.

The motorized damper, Configuration B, can be controlled by an optional relay that allows additional external control with a choice of 24, 120 or 240V coils to regulate fresh air ventilation in response to a control located remote from the Classic heat pump.

GreenWheel® ERV (Configuration H). Setting the correct air flow for the GreenWheel ERV requires a balometer and a screwdriver.

- a. Using best industry standards and practices, measure the fresh air that is being brought into the classroom. For units with one speed controller (std.), adjust the speed of the intake and exhaust blowers by inserting a slotted screw driver into the opening on the controller. The speed controller is located on the lower right side of the GreenWheel® ERV assembly. Access to the speed controller

is through the return air grille. Measure the intake air again and adjust the speed of the blowers. Repeat as necessary to meet the fresh air requirements.

- b. For units with the optional variable fan speed controller for the GreenWheel® ERV exhaust blower, first measure the air being introduced into the classroom using best industry standards and practices. Adjust the speed of the intake air GreenWheel ERV blower until the required outside air is being brought into the classroom.
- c. Now measure the exhaust air from the classroom. Adjust the speed of the exhaust air GreenWheel® ERV blower until the required air is being exhausted from the classroom. The exhaust air controller is located on the lower left side of the GreenWheel ERV assembly. Access to the exhaust air controller is through the return air grille. It is usual practice to pressurize the classroom by exhausting slightly less air than is being brought into the classroom.

Evaporator Variable Fan Speed Controller (Optional)

Indoor evaporator fan controller is accessed through the return air opening. The controller is located on the GreenWheel® ERV assembly on the air separation box in a 2" x 4" "J" box.

Note: Sufficient airflow is required for proper operation of the unit.

GreenCube ERV Ventilation (Configuration Q). Setting the correct air flow for the GreenCube® ERV requires a balometer and a screwdriver.

- a. Using best industry standards and practices, measure the fresh air that is being brought into the classroom.
- b. Now measure the air being introduced into the classroom using best industry standards and practices. Adjust the speed of the intake air GreenCube® ERV blower until the required outside air is being brought into the classroom.
- c. Next measure the exhaust air from the classroom. Adjust the speed of the exhaust air GreenCube® ERV blower until the required air is being exhausted from the classroom. The exhaust air controller is located on the lower left side of the GreenCube® ERV assembly. Access to the exhaust air controller is through the return air grille. It is usual practice to pressurize the classroom by exhausting slightly less air than is being brought into the classroom.

Troubleshooting

4.1 Overview

A comprehensive understanding of the operation of the Classic Heat Pump is a prerequisite to troubleshooting. Please read the Chapter 1 for basic information about the unit.

Marvair® Classic Heat Pumps are thoroughly tested before they are shipped from the factory. Of course, it is possible that a defect may escape undetected, or damage may have occurred during transportation. However, the great majority of problems result from installation errors.

If you experience difficulties with the Classic Heat Pump, please review the installation steps in Chapter 2.

Much time can be saved by taking a thoughtful and orderly approach to troubleshooting. Start with a visual check - are there loose wires, crimped tubing, missing parts, etc? Begin deeper analysis only after making this initial inspection.

The troubleshooting information in this manual is basic. The troubleshooting section contains problem / solution charts for general problems, followed by a compressor section.

Not every problem can be anticipated. If you discover a problem that is not covered in this manual, we would be very grateful if you would bring it to the attention of our service department for incorporation in future revisions.

As always, please exercise caution and good judgement when servicing the Classic Heat Pump. Use only safe and proven service techniques. Use refrigeration goggles when servicing the refrigeration circuit.

The refrigerant circuit has hot surfaces, and the electrical voltages inside of the unit may be hazardous or lethal. **SERVICE MAY BE PERFORMED ONLY BY QUALIFIED AND EXPERIENCED PERSONS.**

 WARNING
The refrigerant circuit has hot surfaces, and the electrical voltages inside of the unit may be hazardous or lethal. SERVICE MAY BE PERFORMED <u>ONLY</u> BY QUALIFIED AND EXPERIENCED PERSONS.

4.2 Failure Symptoms Guide

PROBLEM/SYMPTOM	LIKELY CAUSE(S)	CORRECTION
<p>A. Unit does not run.</p> <p>NOTE: An internal anti-short-cycle timer will prevent the unit from starting for .2 to 8 minutes following start-up.</p>	<ol style="list-style-type: none"> 1. Power supply problem. 2. Tripped internal disconnect. 3. Shut off by external thermostat or thermostat is defective. 4. Unit off on high pressure or loss of charge. 5. Internal component or connection failure. 	<ol style="list-style-type: none"> 1. Check power supply for adequate phase and voltage. Check wiring to unit and external breakers or fuses. 2. Check circuit protection devices for continuity. 3. Check operation of wall-mounted thermostat. 4. Reset lockout. See section 1.4. 5. Check for loose wiring. Check components for failure.
<p>B. Unit runs for long periods or continuously; cooling is insufficient.</p>	<ol style="list-style-type: none"> 1. Unit undersized for job. 2. Low refrigerant. 3. Component failure. 4. Dirty filter or reduced airflow. 	<ol style="list-style-type: none"> 1. Add additional units for greater capacity. 2. Check for proper charge and possible refrigerant leak. 3. Check internal components, especially compressor for proper operation. 4. Check air filter(s). Check blower operation. Remove airflow restriction.

PROBLEM/SYMPTOM	LIKELY CAUSE(S)	CORRECTION
C. Unit cycles on high pressure or loss of charge.	<ol style="list-style-type: none"> 1. Loss or restriction of airflow. 2. Restriction in refrigerant circuit. 3. Refrigerant overcharge (following field service) 4. Defective high pressure control or loss of charge switch. 	<ol style="list-style-type: none"> 1. Check blower assembly for proper operation. Look for airflow restrictions, e.g., the air filter. Check blower motor and condenser fan. Indoor blower fan speed control set too low. 2. Check for blockage or restriction, especially filter drier and capillary tube assembly. 3. Evacuate and recharge to factory specifications. 4. Check limit cutout pressures. Control is set to actuate at approximately 40 PSIG (loss of charge) and 610 PSIG (high pressure).
D. Unit blows fuses or trips circuit breaker.	<ol style="list-style-type: none"> 1. Inadequate circuit ampacity. 2. Short, loose, or improper connection in field wiring. 3. Internal short circuit. Loose or improper connection(s) in unit. 4. Excessively high or low supply voltage or phase loss (3ϕ only). 	<ol style="list-style-type: none"> 1. Note electrical requirements in Chapter 2 and correct as necessary. 2. Check field wiring for errors. 3. Check wiring in unit. See wiring and schematic diagrams. Test components (especially the compressor) for shorts. 4. Note voltage range limitations specific to the compressor troubleshooting section.
E. Water on floor near unit.	<ol style="list-style-type: none"> 1. Obstruction in condensate line. 2. Obstruction or leak in condensate pan. 3. Unit is not level. 	<ol style="list-style-type: none"> 1. Check for clog or restriction. 2. Check pan for leak or blockage. 3. Level unit.
F. No space heating or reduced heating (units equipped with resistance elements)	<ol style="list-style-type: none"> 1. Defective heating element(s). 2. Thermal limit open. 3. Defective heater contactor. 4. Thermostat set too low. 5. Compressor fault. 	<ol style="list-style-type: none"> 1. Check resistance element(s) for continuity. 2. Check continuity across thermal limit switch. 3. Check relay for proper operation. Replace if defective. 4. Adjust thermostat. 5. Reset the lock out relay at the thermostat.

4.3 Compressor Troubleshooting

Obtain the heat pump's model number and serial number, the compressor's model number and contact Marvair® for compressor specifications.

It is important to rule out other component failures before condemning the compressor.

The following electrical tests will aid diagnosis on single phase "HPA" units:

1. **Start-Up Voltage:** Measure the voltage at the compressor contactor during start-up. The voltage must exceed the minimum shown in Table 8, section 2.2, or compressor failure is likely. A low voltage condition must be corrected.

2. **Running Amperage:** Connect a clip-on type ammeter to the (common) lead to the compressor. Turn on the supply voltage and energize the unit. The compressor will initially draw high amperage; it should soon drop to the RLA value or less. If the amperage stays high, check the motor winding resistances.

NOTE: Feel the top of the compressor to see if it has overheated. If it is hot, the internal overload may be open. You may have to wait several hours for it to reset.
3. **High Voltage/Insulation Test:** Test internal leakage with a megohmmeter. Attach one lead to the compressor case on a bare metal tube and to each compressor terminal to test the motor windings. A short circuit at a high voltages indicates a motor defect. Do not do this test under vacuum.
4. On single phase models, check the capacitor by substitution.

4.4 Electric Heat Controls

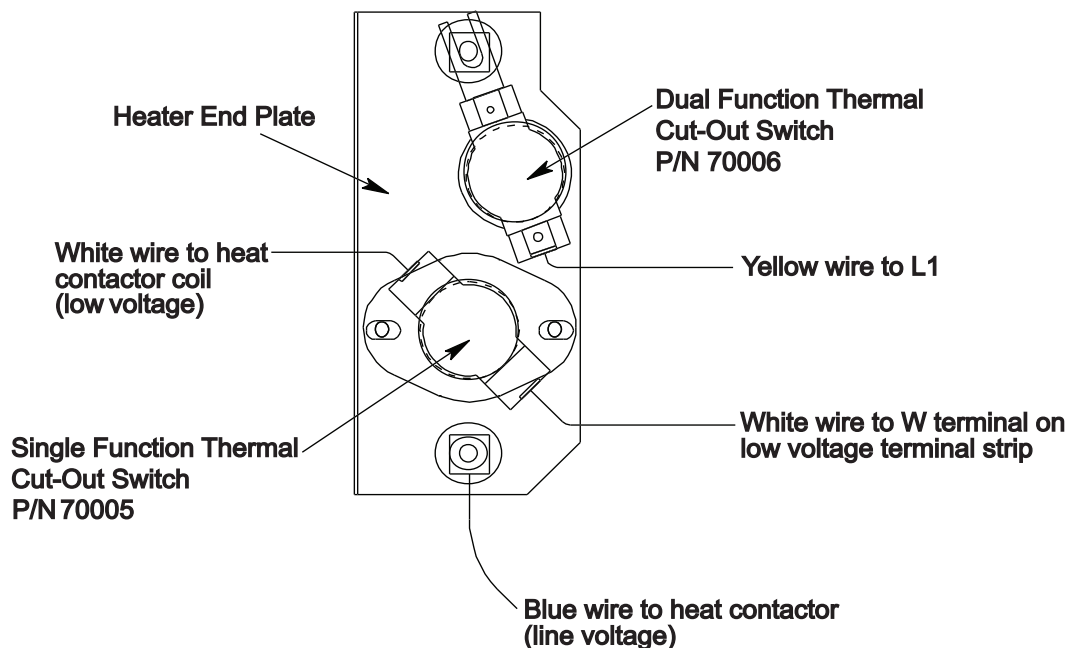

Figure 10 - Typical Configuration for Single Element Heater

The electric heater assembly can have up to three individual heating elements. Each individual heating element is protected against overheating by its own dual function thermal cut-out switch. Additionally, a separate single function thermal cut-out switch protects the entire heater assembly.

The dual function thermal cut-out switch (P/N 70006) is composed of two independent line voltage snap-disc temperature switches mounted in a single enclosure. One of these switches is an automatic reset device which cycles off at approximately 145°F and back on at approximately 115°F. Should this switch fail to open, the second switch will open the circuit if the temperature continues to increase. This second switch does not reset. If it opens (breaks the line voltage circuit to the heater assembly) the switch will have to be replaced by qualified service personnel after the source of the overheat problem is resolved.

In addition to the thermal cut-out switch described above, there is a single function thermal cut-out switch (P/N 70005) mounted on the heater frame. This switch controls the 24V AC control current

to the heater contactor(s) which powers all the heating elements. This single function thermal cut-out switch operates totally independent of the dual thermal cut-out switch described above. If the single function switch senses an overheat situation, it opens the control circuit and turns off all of the installed heating elements via the heater contactor(s). Because this switch controls the heater contactor(s), only one switch is required to disconnect power from the contactor(s), regardless of the number of heater elements. This single function switch is also non-resettable, and must be replaced by qualified service personnel after the source of the overheat problem is resolved. This switch would typically open if both elements of the dual thermal cut-out switches failed.

Electrical Schematics

5.1 Electrical Schematics

The compressor and condenser fan are energized with a contactor controlled by a 24 VAC pilot signal.

The condenser (outside fan) motor is energized by the same contactor. However, the motor is cycled on and off by the low ambient control (see low ambient control 1.5). Note: Only on Classic heat pump with economizer.

The compressor incorporates an internal PTC crankcase heater that functions as long as primary power is available. The heater drives liquid refrigerant from the crankcase and prevents loss of lubrication caused by oil dilution. Power must be applied to the unit for 24 hours before starting the compressor. Note: Classic heat pumps with scroll compressors generally do not require crankcase heaters.

The indoor evaporator fan motor is cycled by the blower timed delay relay. See Figure 9. Due to the large number of variations and options available for the Classic heat pumps, it is not practical to include every possible wiring schematic in this manual. The following schematics are typical. Included in each Classic heat pump is the electrical schematic for that unit. Always refer to the schematic in the unit when installing or servicing the heat pump.

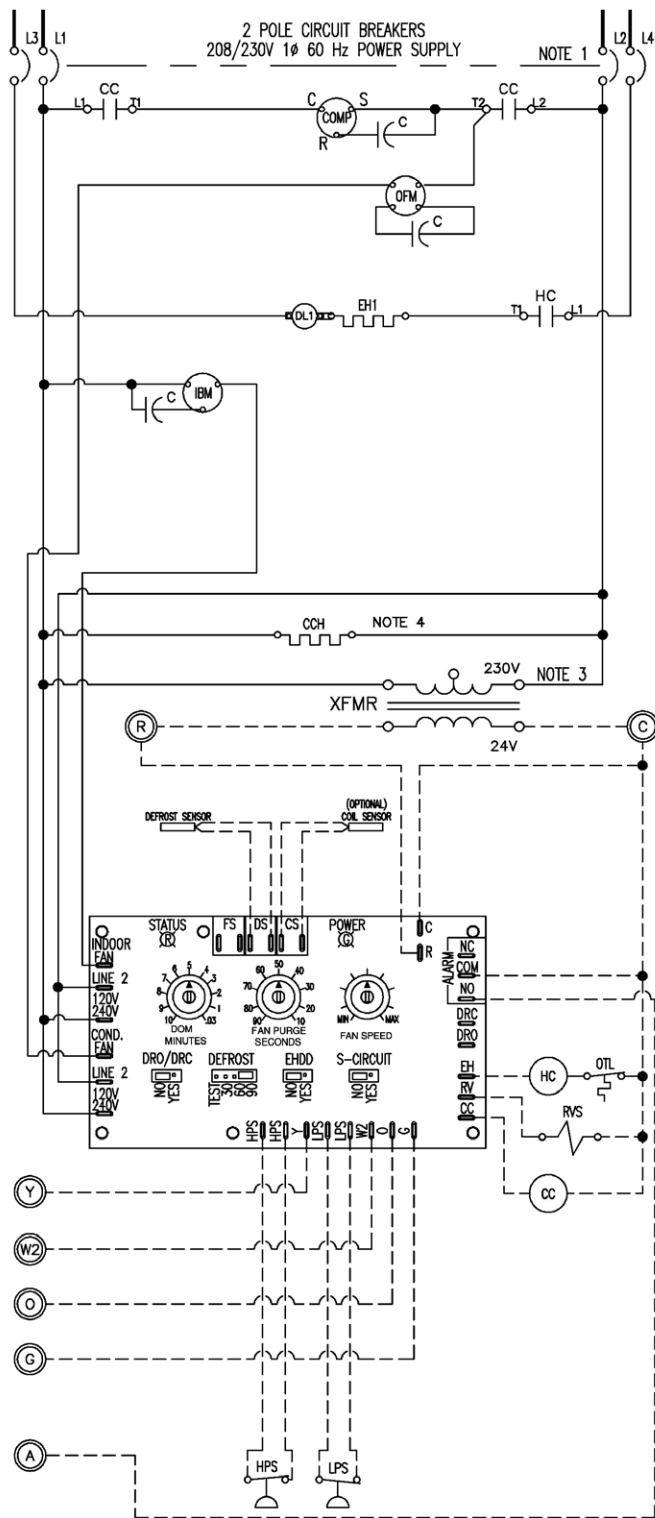

ELECTRICAL LEGEND:

- C CAPACITOR
- CC COMPRESSOR CONTACTOR
- CCH CRANKCASE HEATER
- COMP COMPRESSOR
- DL DUAL LIMIT
- EH ELECTRIC STRIP HEATER
- HPS HIGH PRESSURE SWITCH
- HC HEAT CONTACTOR
- IBM INDOOR BLOWER MOTOR
- LPS LOW PRESSURE SWITCH
- OFM OUTDOOR FAN MOTOR
- OTL ONE TIME LIMIT
- RVS REVERSING VALVE SOLENOID
- XFMR TRANSFORMER

VOLTAGE LEGEND

- LINE VOLTAGE FACTORY
- LINE VOLTAGE FIELD
- LOW VOLTAGE FACTORY
- LOW VOLTAGE FIELD
- - - - - ALT. VOLTAGE (FIELD SPEC.)

COLOR CODE

- BK - BLACK
- BL - BLUE
- BR - BROWN
- G - GREEN
- O - ORANGE
- R - RED
- Y - YELLOW
- WHT - WHITE
- BK/RED-BLACK, RED STRIPE

GENERAL NOTES:

1. 208/230 VOLT 1Ø 60 Hz POWER SUPPLY. SEE DATA PLATE FOR AMPACITY AND FUSE SIZE. OPTIONAL CKT BKR SHOWN.
2. SPEED TAP - SEE MOTOR NAMEPLATE FOR WIRE COLORS.
3. TRANSFORMER IS FACTORY WIRED FOR 230 VOLT OPERATION. FOR LOWER VOLTAGES, INTERCHANGE ORANGE AND RED LEADS. INSULATE UNUSED LEADS.
4. CCH MAY NOT BE REQUIRED ON ALL MODELS
5. PTCR IS NOT REQUIRED ON ALL COMPRESSORS.
6. THE (STATUS LED) WILL BLINK ONE TIME AFTER THE HPS (HIGH PRESSURE SWITCH) HAS OPENED TWICE AND THE UNIT WILL LOCKOUT.
7. THE (STATUS LED) WILL BLINK TWICE AFTER THE LPS (LOW PRESSURE SWITCH) HAS OPENED TWICE AND THE UNIT WILL LOCKOUT. THE LOCKOUT CIRCUIT CONTACTS ARE LOCATED ON THE PRINTED CIRCUIT BOARD.
8. THE (STATUS LED) WILL BLINK FOUR TIMES TO INDICATE A DEFROST OR COIL SENSOR FAULT AND THE UNIT WILL CONTINUE TO OPERATE.

**Figure 11a - Typical 1Ø Electrical Schematic Diagram
Classic Heat Pump (Models AVPA) with Manual Outside Air Damper**

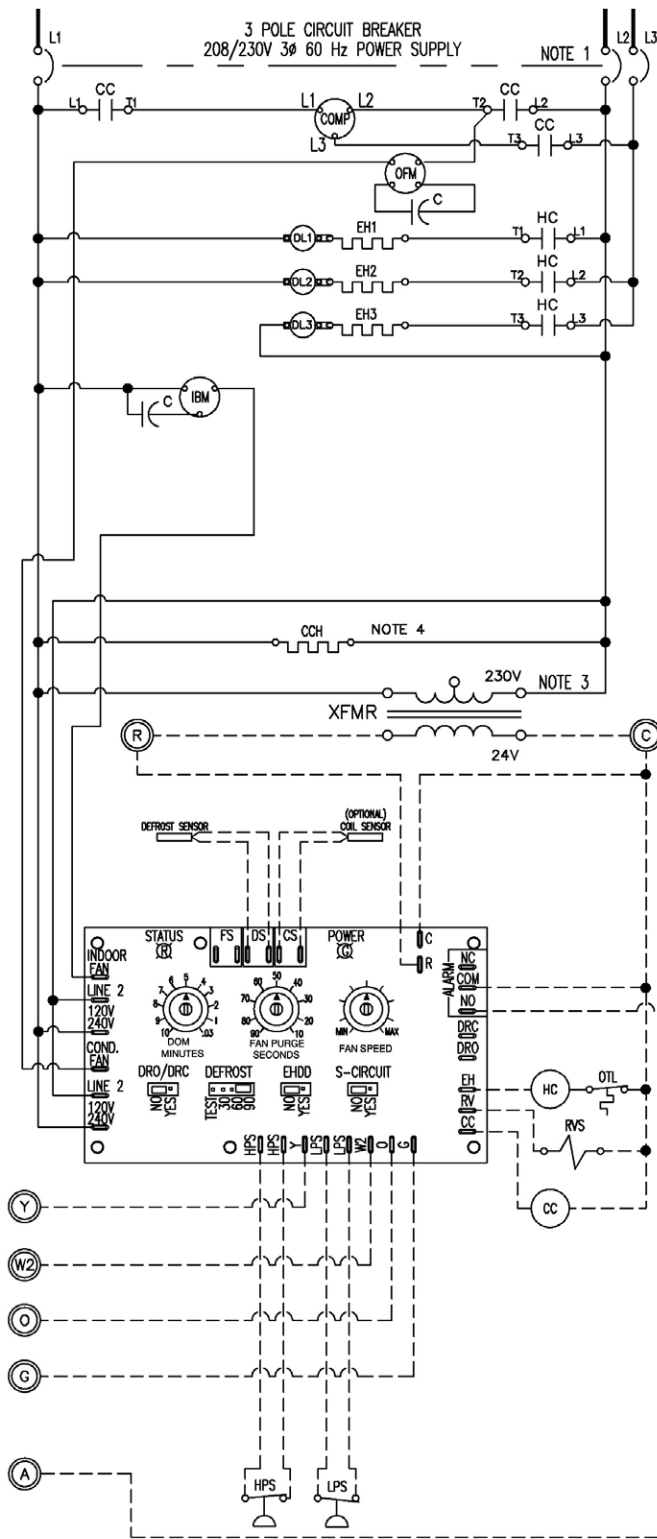

ELECTRICAL LEGEND:

- C CAPACITOR
- CC COMPRESSOR CONTACTOR
- CCH CRANKCASE HEATER
- COMP COMPRESSOR
- DL DUAL LIMIT
- EH ELECTRIC STRIP HEATER
- HPS HIGH PRESSURE SWITCH
- HC HEAT CONTACTOR
- IBM INDOOR BLOWER MOTOR
- LPS LOW PRESSURE SWITCH
- OFM OUTDOOR FAN MOTOR
- OTL ONE TIME LIMIT
- RVS REVERSING VALVE SOLENOID
- XFMR TRANSFORMER

VOLTAGE LEGEND

- LINE VOLTAGE FACTORY
- LINE VOLTAGE FIELD
- LOW VOLTAGE FACTORY
- LOW VOLTAGE FIELD
- - - - - ALT. VOLTAGE (FIELD SPEC.)

COLOR CODE

- BK - BLACK
- BL - BLUE
- BR - BROWN
- G - GREEN
- O - ORANGE
- R - RED
- Y - YELLOW
- WHT - WHITE
- BK/RED - BLACK, RED STRIPE

GENERAL NOTES:

1. 208/230 VOLT 3Ø 60 Hz POWER SUPPLY. SEE DATA PLATE FOR AMPACITY AND FUSE SIZE. OPTIONAL CKT BKR SHOWN.
2. FACTORY PROGRAMMED ECM MOTOR.
3. TRANSFORMER IS FACTORY WIRED FOR 230 VOLT OPERATION. FOR LOWER VOLTAGES, INTERCHANGE ORANGE AND RED LEADS. INSULATE UNUSED LEADS.
4. CCH MAY NOT BE REQUIRED ON ALL MODELS
5. PTCR IS NOT REQUIRED ON ALL COMPRESSORS.
6. THE (STATUS LED) WILL BLINK ONE TIME AFTER THE HPS (HIGH PRESSURE SWITCH) HAS OPENED TWICE AND THE UNIT WILL LOCKOUT.
7. THE (STATUS LED) WILL BLINK TWICE AFTER THE LPS (LOW PRESSURE SWITCH) HAS OPENED TWICE AND THE UNIT WILL LOCKOUT. THE LOCKOUT CIRCUIT CONTACTS ARE LOCATED ON THE PRINTED CIRCUIT BOARD.
8. THE (STATUS LED) WILL BLINK FOUR TIMES TO INDICATE A DEFROST OR COIL SENSOR FAULT AND THE UNIT WILL CONTINUE TO OPERATE.

**Figure 11b - Typical 208/230v. 3Ø Electrical Schematic Diagram
Classic Heat Pump (Models AVPA)**

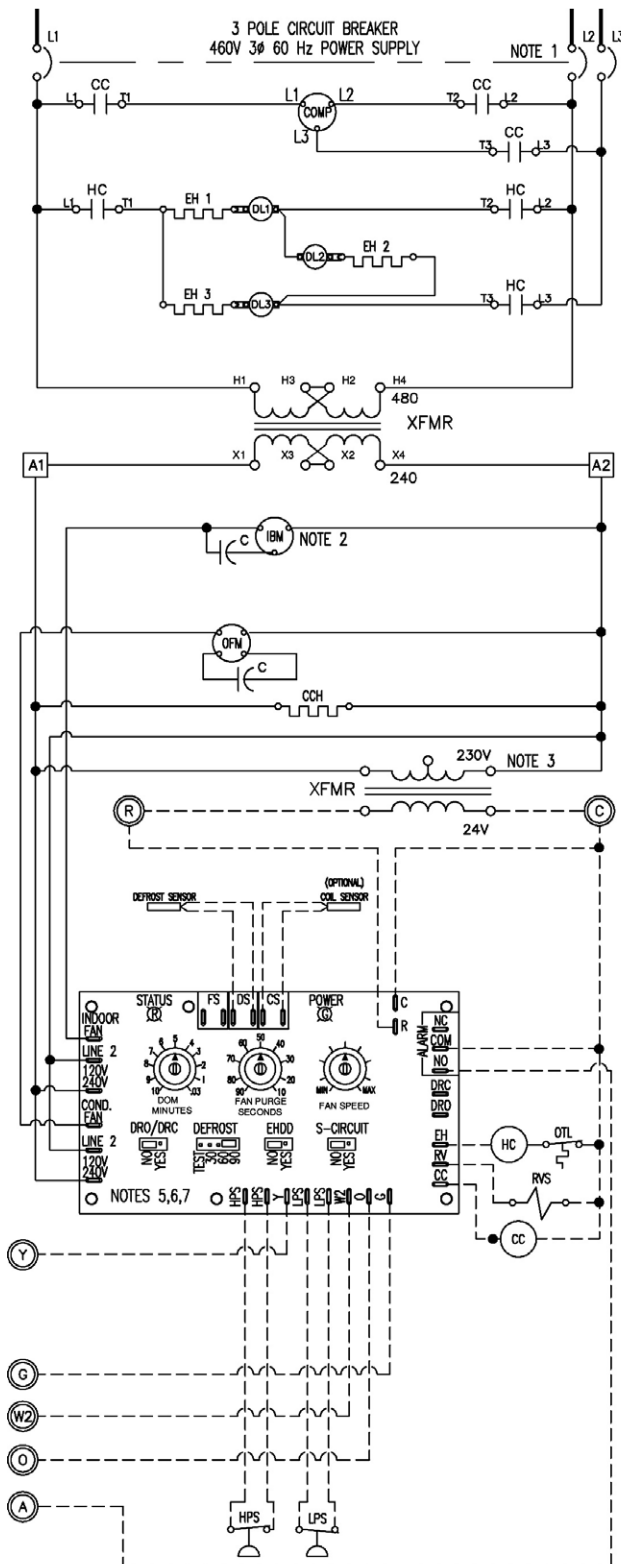

ELECTRICAL LEGEND:

- C CAPACITOR
- CC COMPRESSOR CONTACTOR
- CCH CRANKCASE HEATER
- COMP COMPRESSOR
- DL DUAL LIMIT
- EH ELECTRIC HEAT
- HC HEAT CONTACTOR
- HPS HIGH PRESSURE SWITCH
- IBM INDOOR BLOWER MOTOR
- LPS LOW PRESSURE SWITCH
- OFM OUTDOOR FAN MOTOR
- OTL ONE TIME LIMIT
- RVS REVERSING VALVE SOLENOID
- XFMR TRANSFORMER

VOLTAGE LEGEND

- LINE VOLTAGE FACTORY
- LINE VOLTAGE FIELD
- LOW VOLTAGE FACTORY
- LOW VOLTAGE FIELD
- - - - - ALT. VOLTAGE (FIELD SPEC.)

COLOR CODE

- BK - BLACK
- BL - BLUE
- BR - BROWN
- G - GREEN
- O - ORANGE
- R - RED
- Y - YELLOW
- WHT - WHITE
- BK/RED - BLACK, RED STRIPE

GENERAL NOTES:

1. 460 VOLT 3 ϕ 60 Hz POWER SUPPLY. SEE DATA PLATE FOR AMPACITY AND FUSE SIZE. OPTIONAL CKT BKR SHOWN.
2. SPEED TAP - SEE MOTOR NAMEPLATE FOR WIRE COLORS.
3. TRANSFORMER IS FACTORY WIRED FOR 230 VOLT OPERATION. FOR LOWER VOLTAGES, INTERCHANGE ORANGE AND RED LEADS. INSULATE UNUSED LEADS.
4. CRANKCASE MAY NOT BE REQUIRED ON ALL COMPRESSORS.
5. THE (STATUS LED) WILL BLINK ONE TIME AFTER THE HPS (HIGH PRESSURE SWITCH) HAS OPENED TWICE AND THE UNIT WILL LOCKOUT.
6. THE (STATUS LED) WILL BLINK TWICE AFTER THE LPS (LOW PRESSURE SWITCH) HAS OPENED TWICE AND THE UNIT WILL LOCKOUT. THE LOCKOUT CIRCUIT CONTACTS ARE LOCATED ON THE PRINTED CIRCUIT BOARD.
7. THE (STATUS LED) WILL BLINK FOUR TIMES TO INDICATE A DEFROST OR COIL SENSOR FAULT AND THE UNIT WILL CONTINUE TO OPERATE.

**Figure 11c, Typical 460v. 3 ϕ Electrical Schematic Diagram
Classic Heat Pumps, Models AVPA, with the PC Control Board**

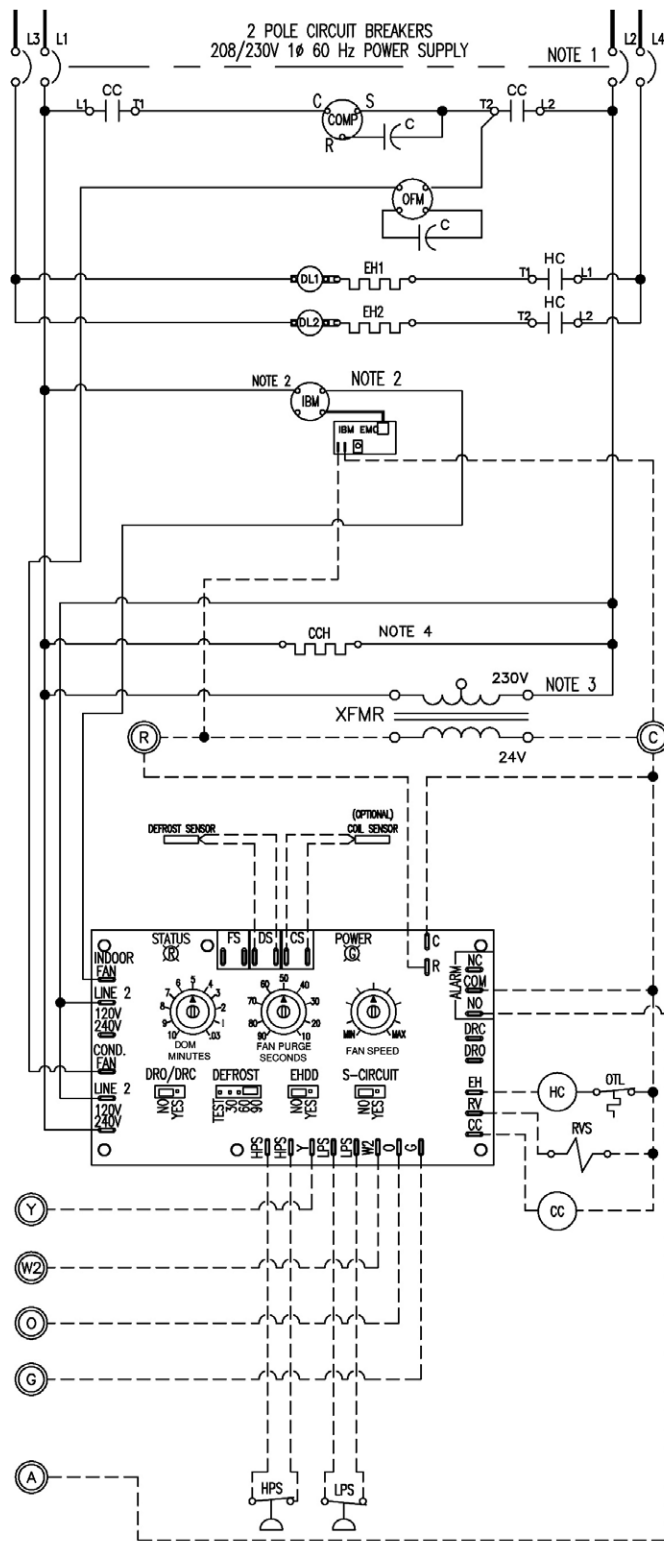

ELECTRICAL LEGEND:

BTR	BLOWER TIME RELAY
C	CAPACITOR
CC	COMPRESSOR CONTACTOR
CCH	CRANKCASE HEATER
COMP	COMPRESSOR
DL	DUAL LIMIT
EH	ELECTRIC STRIP HEATER
EMC	ELECTRONIC MOTOR CONTROL
HPS	HIGH PRESSURE SWITCH
HC	HEAT CONTACTOR
IBM	INDOOR BLOWER MOTOR
LPS	LOW PRESSURE SWITCH
OFM	OUTDOOR FAN MOTOR
OTL	ONE TIME LIMIT
RVS	REVERSING VALVE
XFMR	TRANSFORMER

VOLTAGE LEGEND

—————	LINE VOLTAGE FACTORY
—————	LINE VOLTAGE FIELD
-----	LOW VOLTAGE FACTORY
-----	LOW VOLTAGE FIELD
-----	ALT. VOLTAGE (FIELD SPEC.)

COLOR CODE

BK	BLACK	O	ORANGE
BL	BLUE	R	RED
BR	BROWN	Y	YELLOW
G	GREEN		WHT-WHITE
BK/RED-BLACK, RED STRIPE			

GENERAL NOTES:

1. 208/230 VOLT 1Ø 60 Hz POWER SUPPLY. SEE DATA PLATE FOR AMPACITY AND FUSE SIZE. OPTIONAL CKT BKR SHOWN.
2. FACTORY PROGRAMMED ECM MOTOR.
3. TRANSFORMER IS FACTORY WIRED FOR 230 VOLT OPERATION. FOR LOWER VOLTAGES, INTERCHANGE ORANGE AND RED LEADS. INSULATE UNUSED LEADS.
4. CCH MAY NOT BE REQUIRED ON ALL MODELS
5. PTCR IS NOT REQUIRED ON ALL COMPRESSORS.
6. THE (STATUS LED) WILL BLINK ONE TIME AFTER THE HPS (HIGH PRESSURE SWITCH) HAS OPENED TWICE AND THE UNIT WILL LOCKOUT.
7. THE (STATUS LED) WILL BLINK TWICE AFTER THE LPS (LOW PRESSURE SWITCH) HAS OPENED TWICE AND THE UNIT WILL LOCKOUT. THE LOCKOUT CIRCUIT CONTACTS ARE LOCATED ON THE PRINTED CIRCUIT BOARD.
8. THE (STATUS LED) WILL BLINK FOUR TIMES TO INDICATE A DEFROST OR COIL SENSOR FAULT AND THE UNIT WILL CONTINUE TO OPERATE.

**Figure 11d - Typical Electrical Schematic Diagram
Classic Heat Pump (Models HVPA) with Manual Outside Air Damper**

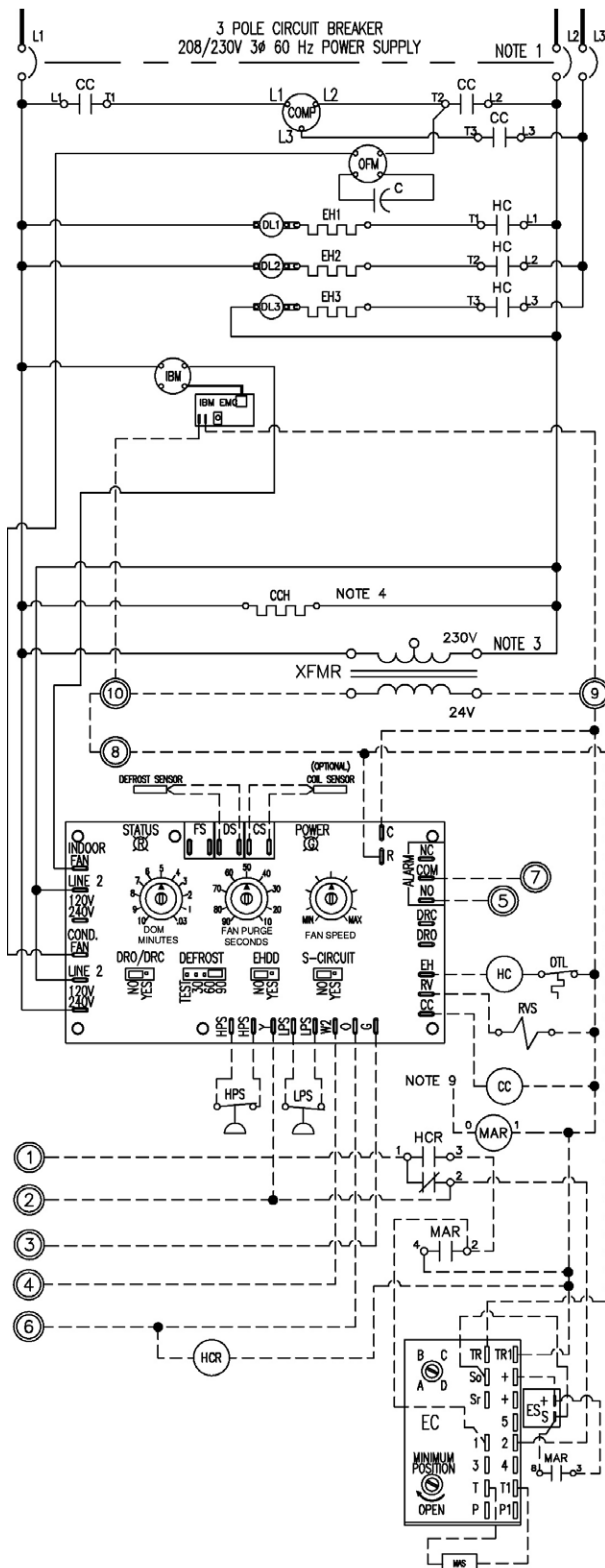

ELECTRICAL LEGEND:

- C CAPACITOR
- CC COMPRESSOR CONTACTOR
- CCH CRANKCASE HEATER
- COMP COMPRESSOR
- DL DUAL LIMIT
- EC ENTHALPY CONTROL
- EH ELECTRIC STRIP HEATER
- EMC ELECTRONIC MOTOR CONTROL
- HPS HIGH PRESSURE SWITCH
- HC HEAT CONTACTOR
- HCR HEAT COOL RELAY
- IBM INDOOR BLOWER MOTOR
- LPS LOW PRESSURE SWITCH
- MAR MIXED AIR RELAY
- MAS MIXED AIR SENSOR
- OFM OUTDOOR FAN MOTOR
- OTL ONE TIME LIMIT
- RVS REVERSING VALVE SOLENOID
- XFMR TRANSFORMER

VOLTAGE LEGEND

- LINE VOLTAGE FACTORY
- LINE VOLTAGE FIELD
- LOW VOLTAGE FACTORY
- LOW VOLTAGE FIELD
- ALT. VOLTAGE (FIELD SPEC.)

COLOR CODE

- BK - BLACK O - ORANGE
- BL - BLUE R - RED
- BR - BROWN Y - YELLOW
- G - GREEN WHT - WHITE
- BK/RED - BLACK, RED STRIPE

GENERAL NOTES:

1. 208/230 VOLT 3 ϕ 60 Hz POWER SUPPLY. SEE DATA PLATE FOR AMPACITY AND FUSE SIZE. OPTIONAL CKT BKR SHOWN.
2. FACTORY PROGRAMMED ECM MOTOR.
3. TRANSFORMER IS FACTORY WIRED FOR 230 VOLT OPERATION. FOR LOWER VOLTAGES, INTERCHANGE ORANGE AND RED LEADS. INSULATE UNUSED LEADS.
4. CCH MAY NOT BE REQUIRED ON ALL MODELS.
5. PTCR IS NOT REQUIRED ON ALL COMPRESSORS.
6. THE (STATUS LED) WILL BLINK ONE TIME AFTER THE HPS (HIGH PRESSURE SWITCH) HAS OPENED TWICE AND THE UNIT WILL LOCKOUT.
7. THE (STATUS LED) WILL BLINK TWICE AFTER THE LPS (LOW PRESSURE SWITCH) HAS OPENED TWICE AND THE UNIT WILL LOCKOUT. THE LOCKOUT CIRCUIT CONTACTS ARE LOCATED ON THE PRINTED CIRCUIT BOARD.
8. THE (STATUS LED) WILL BLINK FOUR TIMES TO INDICATE A DEFROST OR COIL SENSOR FAULT AND THE UNIT WILL CONTINUE TO OPERATE.

Figure 11e - Typical Electrical Schematic Diagram Classic Heat Pump (Models HVPA) with Economizer

6.1 Scheduled Maintenance

Marvair® strongly recommends that the heat pump be serviced a minimum of twice a year – once prior to the heating season and once prior to the cooling season. At this time the filters, evaporator coil, condenser coil, the cabinet, and condensate drains should be serviced as described below. Also at this time, the heat pump should be operated in the cooling and heating cycles as described in Chapter 3, Start-Up. In addition to this seasonal check-out, the unit should be maintained as follows:

Air Filter

Replace the air filter whenever it is visibly dirty. Never operate the heat pump without the filters in place.

Indoor Coil

If the coil becomes clogged or dirty, it may be cleaned by careful vacuuming or with a commercial evaporator cleaning spray. DO NOT use a solvent containing bleach, acetone, or flammable substances. Turn power OFF before cleaning. Be careful not to wet any of the electrical components. Be sure the unit has dried before restarting. Use a fin comb of the correct spacing to straighten mashed or bent fins.

Outdoor Coil

Periodically inspect the outdoor coil and the cabinet air reliefs for dirt or obstructions. Remove foreign objects such as leaves, paper, etc.

If the coil is dirty, it may be washed off with a commercial solvent intended for this purpose. TURN OFF POWER BEFORE CLEANING! Be sure that all electrical components are thoroughly dry before restoring power.

Cabinet

The cabinet may be cleaned with a sponge and warm, soapy water or a mild detergent. Do not use bleach, abrasive chemicals or harmful solvents.

Drains

Regularly check the primary and secondary condensate drains. The secondary drain has a stand pipe. An obstruction will force water to dump into the middle of the unit and drain out the sides of the Classic Heat Pump, causing discoloration of the side panels. If discoloration is noted, service the drains.

If a commercial drain solvent is used, flush out the drain pan and system with plenty of fresh water to prevent corrosion.

Lubrication

Oiling of the condenser fan motor or the evaporator blower motor is not recommended.

Warranty

7.1 Limited Product Warranty

If any part of your Marvair® Air Conditioner, Heat Pump or Unit Ventilator fails because of a manufacturing defect within fifteen months from the date of original shipment from Marvair or within twelve months from the date of original start-up, whichever is the earlier date, Marvair will furnish without charge, EXW Cordele, Georgia, the required replacement part. Any transportation, related service labor, diagnosis calls, filter, driers, and refrigerant are not included. The owner must provide proof of the date of the original start-up. The owner's registration card filed with Marvair, the contractor's invoice, the certificate of occupancy or similar document are examples of proof of the date of the original start-up.

In addition, if the hermetic compressor fails because of a manufacturing defect within sixty months from the date of original shipment from Marvair®, Marvair will furnish without charge, EXW Cordele, Georgia, the required replacement part. Any related service labor, diagnosis calls, filter, driers and refrigerant are not included. Marvair will pay for non-priority shipping costs of the compressor during the first twelve months of the warranty period. After the first twelve months of the warranty period, all costs of shipment and risk of loss during the shipment of the compressor shall be the responsibility of the owner.

The owner of the product may ship the allegedly defective or malfunctioning product or part to Marvair®, at such owner's expense, and Marvair will diagnose the defect and, if the defect is covered under this warranty, Marvair will honor its warranty and furnish the required replacement part. All costs for shipment and risk of loss during shipment of the product to Marvair and back to the owner shall be the responsibility and liability of the owner. Upon written request by an owner, Marvair may arrange for remote diagnosis of the allegedly defective or malfunctioning product or part but all costs for transportation, lodging and related expenses with regard to such diagnostic services shall be the responsibility and liability of the owner.

An owner requesting performance under this Warranty shall provide reasonable access to the allegedly defective or malfunctioning product or part to Marvair® and its authorized agents and employees.

This warranty applies only to products purchased and retained for use within the U.S.A., Canada, and Mexico. This warranty does not cover damage caused by improper installation, misuse of equipment or negligent servicing.

THIS WARRANTY CONSTITUTES THE EXCLUSIVE REMEDY OF ANY PURCHASER OF A MARVAIR® HEAT PUMP OR AIR CONDITIONER AND IS IN LIEU OF ALL OTHER WARRANTIES, EXPRESSED OR IMPLIED, INCLUDING, WITHOUT LIMITATION, ANY IMPLIED WARRANTY OF MERCHANTABILITY OR FITNESS FOR USE, TO THE FULLEST EXTENT PERMITTED BY LAW. IN NO EVENT SHALL ANY IMPLIED WARRANTY OF MERCHANTABILITY OR FITNESS FOR USE EXCEED THE TERMS OF THE APPLICABLE WARRANTY STATED ABOVE AND MARVAIR SHALL HAVE NO OTHER OBLIGATION OR LIABILITY. IN NO EVENT SHALL MARVAIR BE LIABLE FOR INCIDENTAL OR CONSEQUENTIAL DAMAGES OR MONETARY DAMAGES.

THIS WARRANTY GIVES YOU SPECIFIC LEGAL RIGHTS, AND YOU MAY ALSO HAVE OTHER RIGHTS WHICH VARY FROM STATE-TO-STATE. Some states do not allow limitations or exclusions, so the above limitations and exclusions may not apply to you.

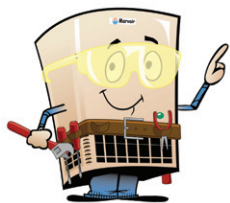

EXPLODED VIEWS AND PARTS LISTS

Current parts lists and exploded views of the unit can be found on our web site at www.marvair.com. Click on the Service and Parts in the menu on the left hand side of the Home page. From the drop down menu, select Exploded Views. Once here, you can select your air conditioner or heat pump. The units are grouped by model and by the refrigerant – R-22 or R-410A.

APPENDIX A: Installation Instructions for Field Installed Electric Heat

WARNING FIRE HAZARD

Improper adjustment, alteration, service, maintenance or installation could cause serious injury, death and/or property damage.

Installation or repairs made by unqualified persons could result in hazards to you and others. Installation **MUST** conform with local codes or, in the absence of local codes, with codes of all governmental authorities have jurisdiction.

The information contained in this manual is intended for use by a qualified service agency that is experienced in such work, is familiar with all precautions and safety procedures required in such work, and is equipped with the proper tools and test instruments.

Duct Work

General Information

Note: The following instructions are for general guidance only. Due to the wide variety of installation possibilities, specific instructions will not be given. When in doubt, follow standard and accepted installation practices, or contact Marvair for additional assistance.

Wall Openings

Measure the dimensions of the supply and return ports on the unit.

Cut the openings in the exterior wall for the supply and return. **IMPORTANT: All units with electric heat must have 1" (25.4 mm) clearance on all four sides of the supply outlet duct flange on the unit. The 1" (25.4 mm) clearance must extend on all sides of the supply duct for the first 3 feet (1 meter) from the unit.**

IMPORTANT: Marvair requires a minimum of 1" (25.4 mm) from the surface of any supply ducts to combustible material for the first 3 feet (1 meter) of the duct.

Ducting

Extensions should be cut flush with the inside wall for applications without duct work.

Applications using duct work should be designed and installed in accordance with all applicable safety codes and standards. Marvair strongly recommends referring to the current edition of the National Fire Protection Association Standards 90A and 90B before designing and installing duct work. The duct system must be engineered to insure sufficient air flow through the unit to prevent over-heating of the heater element. This includes proper supply duct sizing, sufficient quantity of supply registers, adequate return and filter area. Ductwork must be of correct material and must be properly insulated. Duct work must be constructed of galvanized steel with a minimum thickness of .019 inches for the

first 3 feet (1 meter). Ductwork must be firmly attached, secured and sealed to prevent air leakage. Do not use duct liner on inside of supply duct within 4 feet (122 cm) of the unit. Galvanized metal duct extensions should be used to simplify connections to duct work and grilles. Use fabric boots to prevent the transmission of vibration through the duct system. The fabric must be U.L. rated to a minimum of 197°F (92°C).

 **WARNING**
ELECTRICAL SHOCK HAZARD

Failure to follow safety warnings exactly could result in serious injury, death, and/or property damage.

Turn off electrical power at fuse box or service panel BEFORE making any electrical connections and ensure a proper ground connection is made before connecting line voltage.

Heater installation (see drawings and wiring diagram)

1. Remove top front panel.
2. Remove bottom front panel.
3. Remove the control box cover.
4. Remove the heater access cover plate on the upper right side of the unit by removing the three screws. Cut insulation on two sides and fold down out of way.
5. Slide new heater assembly into place by lining up stem with hole on far end. Make sure stem of new heater assembly is inserted into correct hole. The hole nearest to the indoor coil is for three element heaters and the farthest away from indoor coil is for all other heaters.
6. Install the two No. 10 screws in the heater assembly plate.
7. Install wire harness in hole provided in drain pan and then through filter bracket and then into control box.
8. Wire the heater as shown in the wiring diagram provided with the heater kit (the insulated terminal ends are to be connected at the heater).
9. Install pop tie in appropriate hole in back panel to secure wire.
10. Install closed cell strip around wires where they pass through the drain pan.
11. Reinstall the heater access cover.
12. Mount the heat contactor inside the control box where the mounting holes are provided for the heat contactor.
13. Make the wiring connections inside the control box as shown in the wiring diagram provided with the heater kit. Bundle loose wires with wire ties.
14. With a permanent marker, place an (X) in the space provided next to the heater kit rating of the installed heater on the unit data label.
15. Place the wiring diagram provided with the heater kit inside the zip lock bag which is affixed to the back side of the control box cover.
16. Replace the control box cover, the bottom front cover and the top front panel.

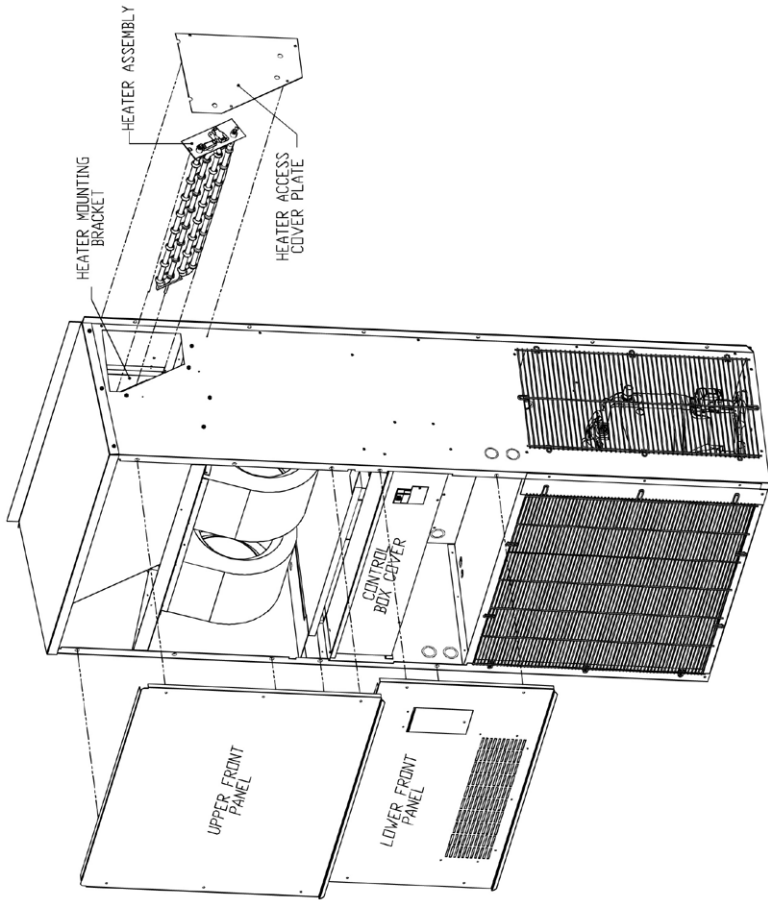

HEATER STEM INSTALLED IN HOLE ON FAR END

HEATER ASSEMBLY INSTALLED WITH TWO #10 SCREWS

