

INSTALLATION INSTRUCTIONS FOR SELF-CONTAINED PACKAGE AIR CONDITIONERS AND HEAT PUMP UNITS GPC/GPH13 & 14 SEER "H" SERIES WITH R-410A

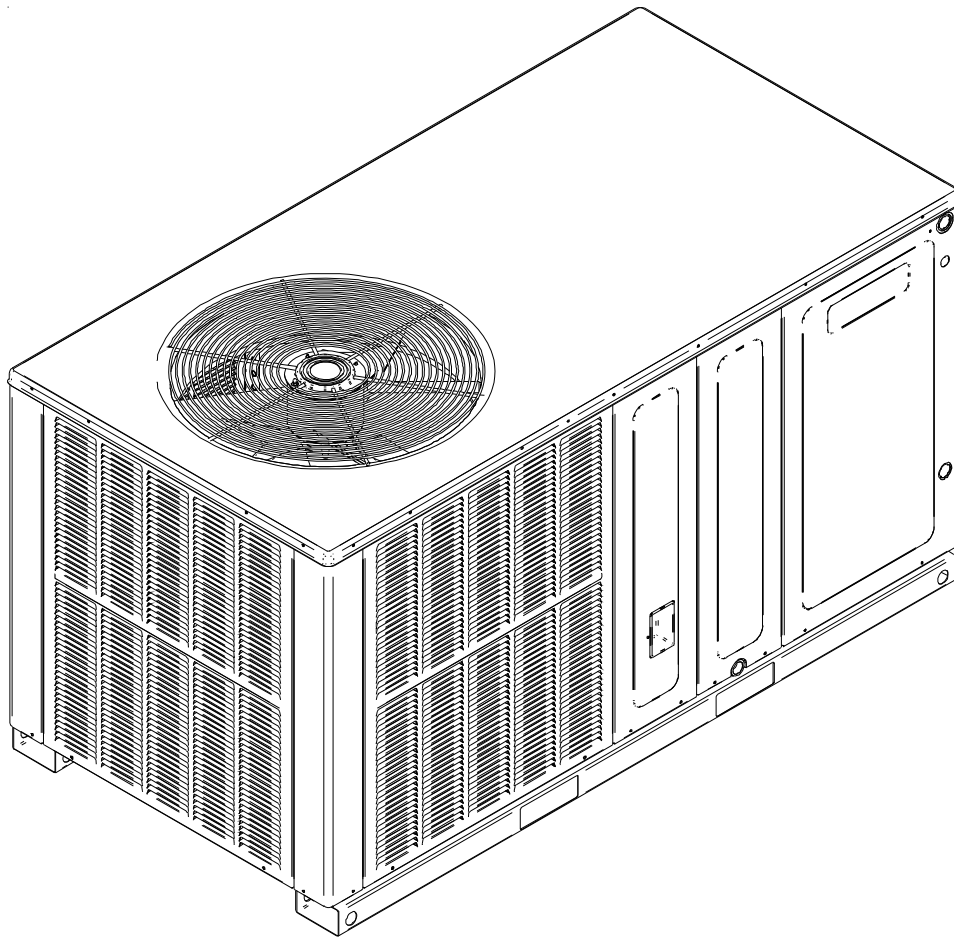

RECOGNIZE THIS SYMBOL AS A SAFETY PRECAUTION.

All information contained herein is subject to change without notice.

ATTENTION INSTALLING PERSONNEL

Prior to installation, thoroughly familiarize yourself with this Installation Manual. Observe all safety warnings.
During installation or repair, caution is to be observed.

It is your responsibility to install the product safely and to educate the customer on its safe use.

These installation instructions cover the **outdoor** installation of self contained package air conditioner and heating units. See the Specification Sheets applicable to your model for information regarding accessories.

***NOTE:** Please contact your distributor or our website for the applicable Specification Sheets referred to in this manual.

IO-398B
7/12



Goodman Manufacturing Company, L.P.
5151 San Felipe, Suite 500, Houston, TX 77056
www.goodmanmfg.com

© 2010-2012 Goodman Manufacturing Company, L.P.



TO THE INSTALLER	2
TO THE OWNER	2
SHIPPING INSPECTION	3
Checking Product Received	3
Message to the Homeowner	3
Before Beginning Installation	3
REPLACEMENT PARTS	3
Ordering Parts	3
IMPORTANT SAFETY INSTRUCTIONS	3
Recognize Safety Symbols, Words, and Labels	3
CODES AND REGULATIONS	4
General	4
EPA Regulations	4
National Codes	4
MAJOR COMPONENTS	4
General	4
INSTALLATION	4
Pre-Installation Checkpoints	4
Clearance	4
Location	4
Outside Slab Installation	4
Rooftop Installation	5
DUCTING	5
Connecting the Return and Supply Flexible Duct in Manufactured or Modular Housing Application	5
Plenum Application	6
Filters	6
PIPING	6
Condensate Drain	6
WIRING	6
High Voltage Wiring	6
Low Voltage Wiring	7
Internal Wiring:	7
OPERATION	7
Start-Up Procedure and Checklist	7
Heat Pump Start-Up Procedure	7
Final System Checks	8
HEAT PUMP REFRIGERANT CIRCUIT	8
COMPONENTS	9
Contactor	9
Crankcase Heater	9
Condenser Motor	9
Compressor	9
Contactor Relay	9
Defrost Control	9
Outdoor Thermostat	9
Reversing Valve Coil	9
Indoor Blower Motor	9
Blower Interlock Relay	9
EXPLANATION AND GUIDANCE (HEAT PUMP)	9
DEFROST CONTROL	10
SUGGESTED FIELD TESTING/TROUBLESHOOTING ..	10

AIR FLOW MEASUREMENT AND ADJUSTMENT	10
ADJUSTING SPEED TAP FOR INDOOR BLOWER MOTOR	10
ELECTRIC HEAT INSTALLATION & ADJUSTMENT ...	11
MAINTENANCE	12
Service	12
Inadequate Air Volume Through Indoor Coil	12
Outside Air Into Return Duct	12
Undercharge	12
Poor “Terminating” Sensor Contact	12
Malfunctioning Reversing Valve	12
BLOWER PERFORMANCE GP* 13/14 SEER	13-14
TROUBLESHOOTING CHART	15

 WARNING
<p>INSTALLATION AND REPAIR OF THIS UNIT SHOULD BE PERFORMED ONLY BY INDIVIDUALS MEETING (AT A MINIMUM) THE REQUIREMENTS OF AN “ENTRY LEVEL TECHNICIAN” AS SPECIFIED BY THE AIR-CONDITIONING, HEATING, AND REFRIGERATION INSTITUTE (AHRI). ATTEMPTING TO INSTALL OR REPAIR THIS UNIT WITHOUT SUCH BACKGROUND MAY RESULT IN PRODUCT DAMAGE, PERSONAL INJURY OR DEATH.</p> 

To THE INSTALLER

Carefully read all instructions for the installation prior to installing unit. Make sure each step or procedure is understood and any special considerations are taken into account before starting installation. Assemble all tools, hardware and supplies needed to complete the installation. Some items may need to be purchased locally. After deciding where to install unit, closely look the location over - both the inside and outside of home. Note any potential obstacles or problems that might be encountered as noted in this manual. Choose a more suitable location if necessary.

IMPORTANT NOTE: If a crankcase heater is used, the unit should be energized 24 hours prior to compressor start up to ensure crankcase heater has sufficiently warmed the compressor. Compressor damage may occur if this step is not followed.

IMPORTANT NOTE TO THE OWNER REGARDING PRODUCT WARRANTY

Your warranty certificate is supplied as a separate document with the unit installed by your contractor. Read the limited warranty certificate carefully to determine what is and is not covered and keep the warranty certificate in a safe place. If you are unable to locate the warranty certificate please contact your installing contractor or contact customer service (877-254-4729) to obtain a copy.

To receive the 10-year Parts Limited Warranty for Goodman® brand products, online registration must be completed within 60 days of installation. Online registration is not required in California or Quebec. Complete warranty details available from your local dealer or at www.goodmanmfg.com.

IMPORTANT: To register your Goodman® brand unit, go to www.goodmanmfg.com and click "Warranty Registration". Complete registration as prompted.

Product limited warranty certificates for models currently in production can be viewed at www.goodmanmfg.com. If your model is not currently in production or does not appear on the website, please contact your installing contractor or contact customer service (877-254-4729) to obtain a copy of your warranty certificate.

Each product overview page contains a Product Warranty link; by clicking on it you will be able to view the limited warranty coverage for that specific product. To view warranty registration information, click on the Product Warranty text on the left navigation panel on the home page of each website. The Online Product Registration pages are located in this same section.

Before using this manual, check the serial plate for proper model identification.

The installation and servicing of this equipment must be performed by qualified, experienced technicians only.

SHIPPING INSPECTION

Checking Product Received

Upon receiving the unit, inspect it for damage from shipment. Claims for damage, either shipping or concealed, should be filed immediately with the shipping company. Check the unit model number, specifications, electrical characteristics and accessories to determine if they are correct. In the event an incorrect unit is shipped, it must be returned to the supplier and must NOT be installed. The manufacturer assumes no responsibility for installation of incorrectly shipped units.

Message to the Homeowner

These instructions are addressed primarily to the installer; however, useful maintenance information is included and should be kept, after installation, for future reference.

Before Beginning Installation

Carefully read all instructions for the installation prior to installing unit. Make sure each step or procedure is understood and any special considerations are taken into account before starting installation. Assemble all tools, hardware and supplies needed to complete the installation. Some items may need to be purchased locally. After deciding where to install unit, closely look the location over - both the inside and outside of home. Note any potential obstacles or problems that might be encountered as noted in this manual. Choose a more suitable location if necessary.

REPLACEMENT PARTS

Ordering Parts

When reporting shortages or damages, or ordering repair parts, give the complete unit model and serial numbers as stamped on the unit's nameplate. Replacement parts for this appliance are available through your contractor or local distributor. For the location of your nearest distributor, consult the white business pages, the yellow page section of the local telephone book or contact:

CONSUMER AFFAIRS
GOODMAN MANUFACTURING COMPANY, L.P.
7401 SECURITY WAY
HOUSTON, TEXAS 77040
877-254-4729

IMPORTANT SAFETY INSTRUCTIONS

Recognize Safety Symbols, Words, and Labels

The following symbols and labels are used throughout this manual to indicate immediate or potential hazards. It is the owner's responsibility to read and comply with all safety information and instructions accompanying these symbols. Failure to heed safety information increases the risk of serious personal injury or death, property damage and/or product damage.

WARNING

DO NOT CONNECT TO OR USE ANY DEVICE THAT IS NOT DESIGN-CERTIFIED BY GOODMAN FOR USE WITH THIS UNIT. SERIOUS PROPERTY DAMAGE, PERSONAL INJURY, REDUCED UNIT PERFORMANCE AND/OR HAZARDOUS CONDITIONS MAY RESULT FROM THE USE OF SUCH NON-APPROVED DEVICES.

WARNING

HIGH VOLTAGE!
DISCONNECT ALL POWER BEFORE SERVICING OR INSTALLING THIS UNIT. MULTIPLE POWER SOURCES MAY BE PRESENT. FAILURE TO DO SO MAY CAUSE PROPERTY DAMAGE, PERSONAL INJURY OR DEATH.



WARNING

CONNECTING UNIT DUCT WORK TO UNAUTHORIZED HEAT PRODUCING DEVICES SUCH AS A FIREPLACE INSERT, STOVE, ETC. MAY RESULT IN PROPERTY DAMAGE, FIRE, CARBON MONOXIDE POISONING, EXPLOSION, PERSONAL INJURY OR DEATH.

WARNING

THIS PRODUCT CONTAINS OR PRODUCES A CHEMICAL OR CHEMICALS WHICH MAY CAUSE SERIOUS ILLNESS OR DEATH AND WHICH ARE KNOWN TO THE STATE OF CALIFORNIA TO CAUSE CANCER, BIRTH DEFECTS OR OTHER REPRODUCTIVE HARM.

WARNING

TO AVOID PROPERTY DAMAGE, PERSONAL INJURY OR DEATH, DO NOT USE THIS UNIT IF ANY PART HAS BEEN UNDER WATER. IMMEDIATELY CALL A QUALIFIED SERVICE TECHNICIAN TO INSPECT THE FURNACE AND TO REPLACE ANY PART OF THE CONTROL SYSTEM AND ANY GAS CONTROL HAVING BEEN UNDER WATER.

WARNING

THIS UNIT MUST NOT BE USED AS A "CONSTRUCTION HEATER" DURING THE FINISHING PHASES OF CONSTRUCTION ON A NEW STRUCTURE. THIS TYPE OF USE MAY RESULT IN PREMATURE FAILURE OF THE UNIT DUE TO EXTREMELY LOW RETURN AIR TEMPERATURES AND EXPOSURE TO CORROSIVE OR VERY DIRTY ATMOSPHERES.

WARNING

TO PREVENT THE RISK OF PROPERTY DAMAGE, PERSONAL INJURY, OR DEATH, DO NOT STORE COMBUSTIBLE MATERIALS OR USE GASOLINE OR OTHER FLAMMABLE LIQUIDS OR VAPORS IN THE VICINITY OF THIS APPLIANCE.

CODES AND REGULATIONS

General

The GPC & GPH series air conditioners and heat pumps are designed for OUTDOOR USE ONLY. This series is available in cooling Capacities of 2, 2 ½, 3, 3 ½, 4 and 5 nominal tons of cooling. Optional field installed heat kits are available in 5,8,10,15 and 20 KW. The units can be easily installed in manufactured or modular homes with existing high-static duct work. The units can also be easily converted to accommodate a plenum for normal or low-static applications.

The GPC & GPH series are self contained packaged units so the only connections needed for installation are the supply and return ducts, the line and low voltage wiring and drain connection. Rated performance is achieved after 72 hours of operation. Rated performance is delivered at the specified airflow. See outdoor unit specification sheet for split system models or product specification sheet for packaged and light commercial models. Specification sheets can be found at www.goodmanmfg.com for Goodman® brand products or www.amana-hac.com for Amana® brand products. Within either website, please select the residential or commercial products menu and then select the submenu for the type of product to be installed, such as air conditioners or heat pumps, to access a list of product pages that each contain links to that model's specification sheet. The units are ETL listed and AHRI certified.

The information on the rating plate is in compliance with the FTC & DOE rating for single phase units. The three phase units in this series are not covered under the DOE certified program. The efficiency ratings of these units are a product of thermal efficiency determined under continuous operating conditions independent of any installed system.

EPA Regulations

IMPORTANT: THE UNITED STATES ENVIRONMENTAL PROTECTION AGENCY (EPA) HAS ISSUED VARIOUS REGULATIONS REGARDING THE INTRODUCTION AND DISPOSAL OF REFRIGERANTS IN THIS UNIT. FAILURE TO FOLLOW THESE REGULATIONS MAY HARM THE ENVIRONMENT AND CAN LEAD TO THE IMPOSITION OF SUBSTANTIAL FINES. BECAUSE REGULATIONS MAY VARY DUE TO PASSAGE OF NEW LAWS, WE SUGGEST A CERTIFIED TECHNICIAN PERFORM ANY WORK DONE ON THIS UNIT. SHOULD YOU HAVE ANY QUESTIONS PLEASE CONTACT THE LOCAL OFFICE OF THE EPA.

National Codes

This product is designed and manufactured to permit installation in accordance with National Codes. It is the installer's responsibility to install the product in accordance with National Codes and/or prevailing local codes and regulations.

MAJOR COMPONENTS

General

The unit includes a hermetically sealed refrigerating system (consisting of a compressor, condenser coil, evaporator coil with flowrator), an indoor blower, a condenser fan and all necessary internal electrical wiring. The heat pump also includes a reversing valve, solenoid, defrost thermostat and control and loss of charge protection. The system is factory-evacuated, charged and performance tested. Refrigerant amount and type are indicated on rating plate.

INSTALLATION

Pre-Installation Checkpoints

Before attempting any installation, the following points should be considered:

- Structural strength of supporting members
- Clearances and provision for servicing
- Power supply and wiring
- Air duct connections
- Drain facilities and connections
- Location may be on any four sides of a home, manufactured or modular, to minimize noise

Clearance

The unit is designed to be located outside the building with unobstructed condenser air inlet and discharge. Additionally, the unit must be situated to permit access for service and installation. Condenser air enters from three sides. Air discharges upward from the top of the unit. Refrigerant gauge connections are made on the right side of the unit as you face the compressor compartment. Electrical connections can be made either on the right or left sides of the unit. The best and most common application is for the unit to be located 10" from wall (4" minimum) with the connection side facing the wall. This "close to the wall" application minimizes exposed wiring.

Close to the wall application assures free, unobstructed air to the other two sides. In more confined application spaces, such as corners provide a minimum 10" clearance on all air inlet sides. Allow 18" minimum for service access to the compressor compartment and controls. The top of the unit should be completely unobstructed. If units are to be located under an overhang, there should be a minimum of 36" clearance and provisions made to deflect the warm discharge air out from the overhang.

Location

Consider the affect of outdoor fan noise on conditioned space and any adjacent occupied space. It is recommended that the unit be placed so that condenser air discharge does not blow toward windows less than 25 feet away.

The unit should be set on a solid, level foundation - preferably a concrete slab at least 4 inches thick. The slab should be above ground level and surrounded by a graveled area for good drainage. Any slab used as a unit's foundation should not adjoin the building as it is possible that sound and vibration may be transmitted to the structure. For rooftop installation, steel or treated wood beams should be used as unit support for load distribution.

Heat pumps require special location consideration in areas of heavy snow accumulation and/or areas with prolonged continuous subfreezing temperatures. Heat pump unit bases have holes under the outdoor coil to permit drainage of defrost water accumulation. The unit must be situated to permit free unobstructed drainage of the defrost water and ice. A minimum 2" clearance under the outdoor coil is required in the milder climates.

Outside Slab Installation (Figure 1)

1. The unit must be mounted on a solid, level foundation.
2. Select a location that will minimize the length of the supply and return ducts.
3. Select a location where external water drainage cannot collect around the unit.
4. Consideration should also be given to shade, appearance and noise.

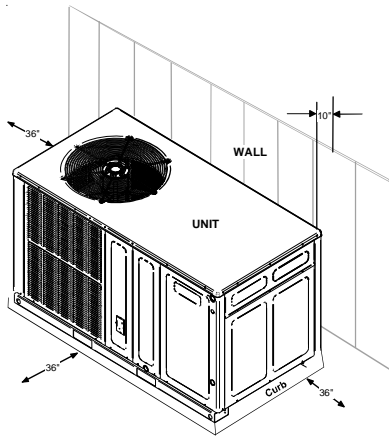

FIGURE 1

Rooftop Installation (Figure 2)

1. Before locating the unit on the roof, make sure that the strength of the roof and beams is adequate to support the weight involved. (See specification sheet for weight of units.) This is very important and the installer's responsibility.
2. Make proper consideration for the weather-tight integrity of the roof and proper drainage of condensate.
3. To ensure proper condensate drainage, unit must be installed in a level position.
4. Consideration should also be given to shade, appearance and noise.

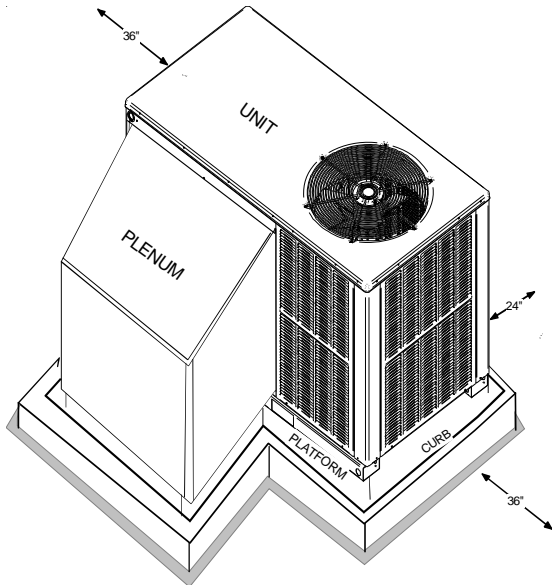

FIGURE 2
DUCTING

⚠ WARNING

DO NOT, UNDER ANY CIRCUMSTANCES, CONNECT RETURN DUCTWORK TO ANY OTHER HEAT PRODUCING DEVICES SUCH AS FIRE-PLACE INSERT, STOVE, ETC. UNAUTHORIZED USE OF SUCH DEVICES MAY RESULT IN PROPERTY DAMAGE, FIRE, CARBON MONOXIDE POISONING, EXPLOSION, PERSONAL INJURY OR DEATH.

Ducting work should be fabricated by the installing contractor in accordance with local codes. Industry manuals may be used as a guide when sizing and designing the duct system—such as NESCA (National Environmental Systems Contractors Association, 1501 Wilson Blvd., Arlington, Virginia 22209).

The unit should be placed as close as possible to the space to be air-conditioned allowing clearance dimensions as indicated. Ducts should run as directly as possible to supply and return outlets. Use of non-flammable weatherproof flexible connectors on both supply and return connections at the unit to reduce noise transmission is recommended.

It is preferable to install the unit on the roof of the structure if the registers or diffusers are located in the wall or ceiling. A slab installation is recommended when the registers are low on the wall or in the floor.

Connecting the Return and Supply Flexible Duct in Manufactured or Modular Housing Application

The return and supply fittings are to be attached at the unit to a suitable square to round duct converter. Your distributor has a factory designed square to round converter transition. The model #'s of these kits are as follows: Small Chassis 25" SQRPCH101, Medium Chassis 27.5" SQRPCH102, Large and Extra Large Chassis 32.5" and 36" SQRPCH103 (See Specification Sheets for Dimension details). The SQRPCH101 has 14" duct collar on supply and 16" duct collar (equivalent diameter, opening is oval) on the return. The SQRPCH102 and SQRPCH103 have 14" duct collar on supply and 18" duct collar (equivalent diameter, opening is oval) on the return. The collars are to be slipped into the openings, and the flanges bent around the converter. The square to round converter is attached to the flanges of the square duct openings. The flexible duct is then clamped on to the collars. Once the duct is affixed to the unit, **seal the collars and flanges with a proper waterproof sealant** (See Figure 3).

It is strongly encouraged to use appropriately sized ducts based upon the CFM for your application (unit's CFM). If duct sizing through industry manuals or air duct calculators require larger ducts than converter openings, run larger duct size up to unit converter openings and reduce with a reducer duct fitting or transition right at the unit.

MINIMUM FILTER SIZE	
NOMINAL SIZE (INCHES)	NOMINAL AREA (SQ. FT.)
10x20	1.4
14x20	1.9
14x25	2.4
15x20	2.1
16x20	2.2
16x25	2.8
20x20	2.8
20x25	3.5
25x25	4.3

TABLE 1

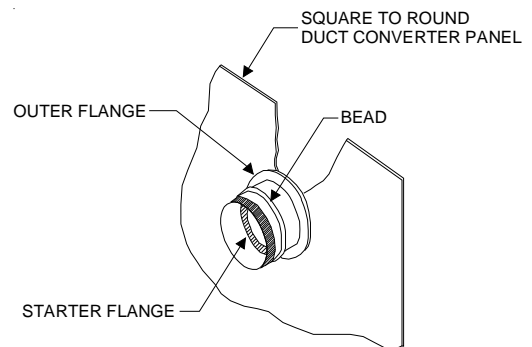

FIGURE 3

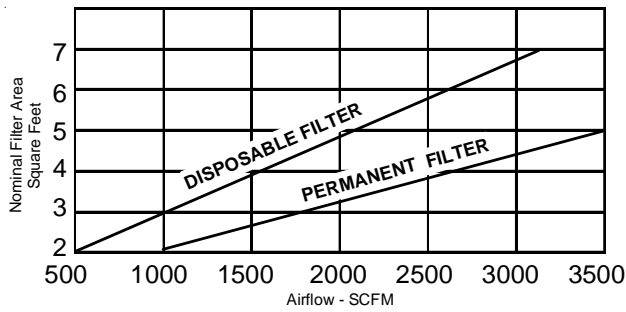

FIGURE 4

Plenum Application

A suitable plenum or square duct must be constructed. The duct cross-sectional area should be determined by industry duct sizing manuals or air duct calculators.

On ductwork exposed to outside air conditions of temperature and humidity, use an insulation with a good K factor, and a vapor barrier. Industry practices should be followed. Balancing dampers are recommended for each branch duct in the supply system. Ductwork should be properly supported from the unit.

NOTE: Proper sealing of all duct work and air handling compartments is extremely important to overall unit efficiency.

Filters

Filters are not provided with unit, and must be supplied and installed in the return duct system by the installer. A field installed filter grille is recommended for easy and convenient access to the filters for periodic inspection and cleaning. Filters must have adequate face area for the rated quantity of the unit. See air delivery tables (Figure 4) for recommended filter size.

PIPING

Condensate Drain

The condensate drain connection of the evaporator is a half coupling of 3/4" N.P.T. A trap must be provided to have Proper condensate drainage.

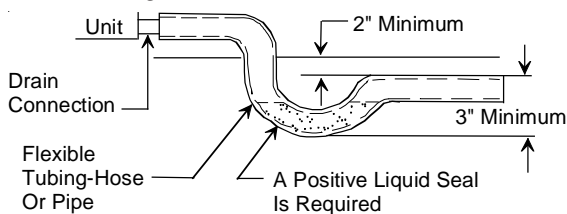

FIGURE 5

Install condensate drain trap as shown. Use 3/4" drain connection size or larger. Do not operate without trap. Unit must be level or slightly inclined toward drain.

WIRING

CAUTION

TO AVOID PROPERTY DAMAGE OR PERSONAL INJURY DUE TO FIRE, USE ONLY COPPER CONDUCTORS.

All wiring should be made in accordance with the National Electrical Code. The local Power Company should be consulted to determine the availability of sufficient power to operate the unit. The voltage, frequency, and phase

at the power supply should be checked to make sure it corresponds to the unit's RATED VOLTAGE REQUIREMENT. Install a branch circuit fused disconnect near the unit, in accordance with the N.E.C. or local codes. Wire sizes and overcurrent protection should be determined from the unit nameplate ampacity and in accordance with Table 4 (page 7) or the N.E.C. Under no circumstances should wiring be sized smaller than is recommended by either of these two sources.

Fuses smaller than that recommended on the wiring diagrams could result in unnecessary fuse failure or service calls. The use of protective devices of larger size than indicated could result in extensive damage to the equipment. The manufacturer bears no responsibility for damage caused to equipment as result of the use of larger than is recommended size protective devices.

All units have undergone a run test prior to packaging for shipment. This equipment has been started at minimum rated voltage and checked for satisfactory operation. Do not attempt to operate this unit if the voltage is not within the minimum and maximum voltages shown on nameplate.

All exterior wiring must be within approved weatherproof conduit. The unit must be **permanently grounded** in accordance with local codes, or in absence of local codes, with N.E.C ANSI/ NFPA NO. 70-1984 or latest edition by using ground lug in the control box.

Fuses or HACR type circuit breakers may be used where codes permit.

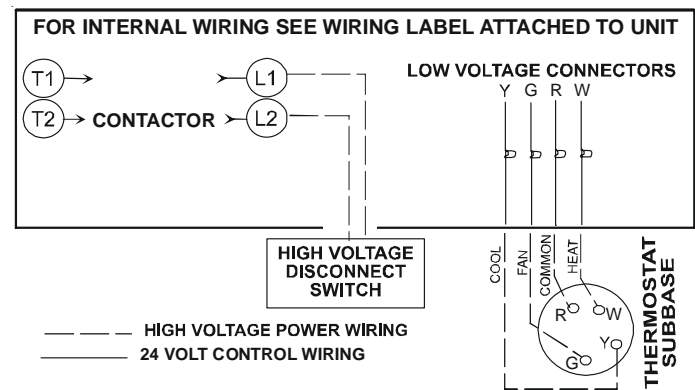

FIGURE 6

Note: Some single phase units are equipped with a single pole contactor. Caution must be exercised when servicing as only one leg of the power supply is broken with the contactor.

To wire the unit, make the following high and low voltage connections.

WARNING

HIGH VOLTAGE! DISCONNECT ALL POWER BEFORE SERVICING OR INSTALLING THIS UNIT. MULTIPLE POWER SOURCES MAY BE PRESENT. FAILURE TO DO SO MAY CAUSE PROPERTY DAMAGE, PERSONAL INJURY OR DEATH.

High Voltage Wiring: (See Figure 6)

Single Phase- Two leads should be connected to terminals L1 & L2 in the electrical control section, using wire sizes specified in wiring table.

Low Voltage Wiring: (See Figure 6)

- a. Air Conditioners- Connect 24V wires from the thermostat to the corresponding wires in the control box using No. 18AWG as follows:

LEAD	THERMOSTAT
Red	R (24V)
Green	G (Fan)
Yellow	Y (Cool)
White	W1 (Heat)*
Brown	W2 (Heat)*

TABLE 2

- b. Heat Pumps- Connect 24V wires from the thermostat to the corresponding wires in the control box using No. 18AWG as follows:

TERMINAL	THERMOSTAT
Red	R (24V)
Green	G (Fan)
Orange	O (Rev. Valve)
White	W1 (Heat, 2nd)*
Brown	W2 (Heat 3rd)*
Yellow	Y (Cool)
C (Blue)	C (Common)

*Optional field installed heat connections

TABLE 3

Internal Wiring:

A diagram detailing the internal wiring of this unit is located on the electrical box cover. If any of the original wire supplied with the appliance must be replaced, the wire gauge and insulation must be the same as the original wiring.

Transformer is wired for 230 volts on the 208/230 models. See wiring diagram for 208 volt wiring.

BRANCH CIRCUIT AMPACITY	15	20	25	30	35	40	45	50
SUPPLY WIRE LENGTH - FEET								
200	6	4	4	4	3	3	2	2
150	8	6	6	4	4	4	3	3
100	10	8	8	6	6	6	4	4
50	14	12	10	10	8	8	6	6

TABLE 4

- For branch circuit wiring (main power supply to unit disconnect), the minimum wire size for the length of the run can be determined from Table 4 using the circuit ampacity found on the unit rating plate. From the unit disconnect to unit, the smallest wire size allowable in Table 4 may be used for the ampacity, **as the Disconnect must be in sight of the unit.**
- Wire size based on 60° C rated wire insulation and 30° C Ambient Temperature (86° F).
- For more than 3 conductors in a raceway or cable, see the N.E.C. for derating the ampacity of each conductor.

OPERATION

Start-Up Procedure and Checklist

Begin with power turned off at all disconnects.



WARNING



HIGH VOLTAGE!
DISCONNECT ALL POWER BEFORE SERVICING OR INSTALLING THIS UNIT. MULTIPLE POWER SOURCES MAY BE PRESENT. FAILURE TO DO SO MAY CAUSE PROPERTY DAMAGE, PERSONAL INJURY OR DEATH.

- Turn thermostat system switch to “Cool,” and fan switch to “Auto” and turn temperature setting as high as it will go.
- Inspect all registers and set them to the normal open position.
- Turn on the electrical supply at the disconnect.
- Turn the fan switch to the “ON” position. The blower should operate after a 7 second delay.
- Turn the fan switch to “Auto” position. The blower should stop after a 65 second delay.
- Slowly lower the cooling temperature until the unit starts. The compressor, blower and fan should now be operating. Allow the unit to run 10 minutes, make sure cool air is being supplied by the unit.
- Turn the temperature setting to the highest position, stopping the unit. The indoor blower will continue to run for 65 seconds.
- Turn the thermostat system switch to “OFF” and disconnect all power when servicing the unit.



WARNING



HIGH VOLTAGE!
DISCONNECT ALL POWER BEFORE SERVICING OR INSTALLING THIS UNIT. MULTIPLE POWER SOURCES MAY BE PRESENT. FAILURE TO DO SO MAY CAUSE PROPERTY DAMAGE, PERSONAL INJURY OR DEATH.

Heat Pump Start-Up Procedure

- Check the cooling mode for the heat pump in the same manner as above. The reversing valve is energized when the thermostat is placed in the cooling position. A clicking sound should be noticeable from the reversing valve. By lowering the temperature setting to call for cooling, the contractor is energized. The compressor, blower and fan should then be running. After the cooling mode is checked out, turn the thermostat system switch to “OFF”.
- Turn the thermostat system switch to “HEAT” and fan switch to “AUTO”.
- Slowly raise the heating temperature setting. When the heating first stage makes contact, stop raising the temperature setting.. The compressor, blower and fan should now be running with the reversing valve in the de-energized (heating) position. After giving the unit time to settle out, make sure the unit is supplying heated air.
- If the out door ambient is above 80°F, the unit may trip on its high pressure cut out when on heating. The compressor should stop. The heating cycle must be thoroughly checked, so postpone the test to another day when conditions are more suitable but-DO NOT FAIL TO TEST.

If the out door ambient is low and the unit operates properly on the heating cycle, you may check the pressure cutout operation by blocking off the indoor return air until the unit trips.

- If unit operates properly in the heating cycle, raise the temperature setting until the heating second stage makes contact. Supplemental resistance heat, if installed should now come on. Make sure it operates properly.

NOTE: If outdoor thermostats are installed the outdoor ambient must be below the set point of these thermostats for the heaters to operate. It may be necessary to jumper these thermostats to check heater operation if outdoor ambient is mild.

- For thermostats with emergency heat switch, return to step 11. The emergency heat switch is located at the bottom of the thermostat. Move the switch to emergency heat. The heat pump will stop, the blower will continue to run, all heaters will come on and the thermostat emergency heat light will come on.
- If checking the unit in the wintertime, when the outdoor coil is cold enough to actuate the defrost control, observe at least one defrost cycle to make sure the unit defrosts completely.

Final System Checks

- Check to see if all supply and return air grilles are adjusted and the air distribution system is balanced for the best compromise between heating and cooling.
- Check for air leaks in the ductwork.
- See Sections on **Air Flow Measurement and Adjustment** and **Checking Charge**.
- Make sure the unit is free of “rattles”, and the tubing in the unit is free from excessive vibration. Also make sure tubes or lines are not rubbing against each other or sheet metal surfaces or edges. If so, correct the trouble.
- Set the thermostat at the appropriate setting for cooling and heating or automatic changeover for normal use.
- Be sure the Owner is instructed on the unit operation, filter, servicing, correct thermostat operation, etc.

The foregoing “Start-up Procedure and Check List” is recommended to serve as an indication that the unit will operate normally.

HEAT PUMP REFRIGERANT CIRCUIT - FIGURE 7

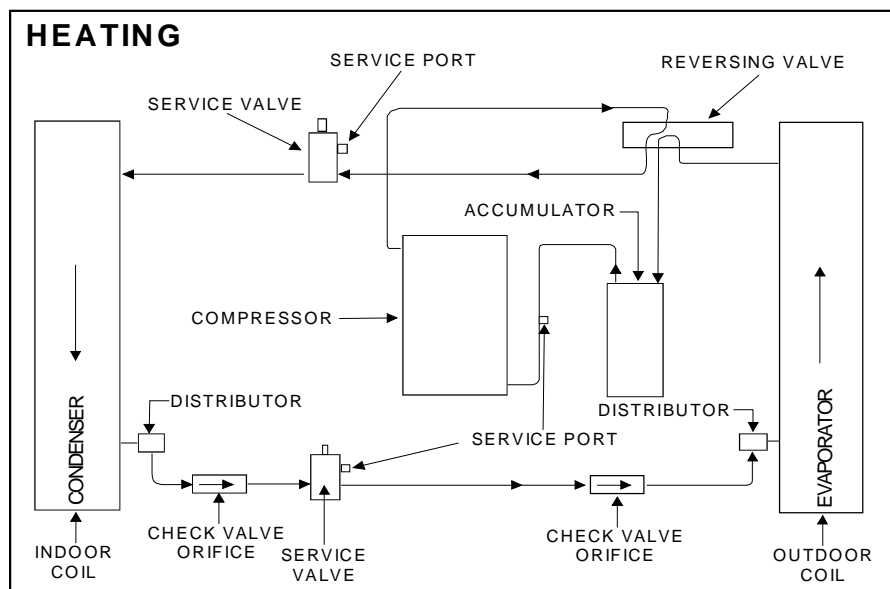
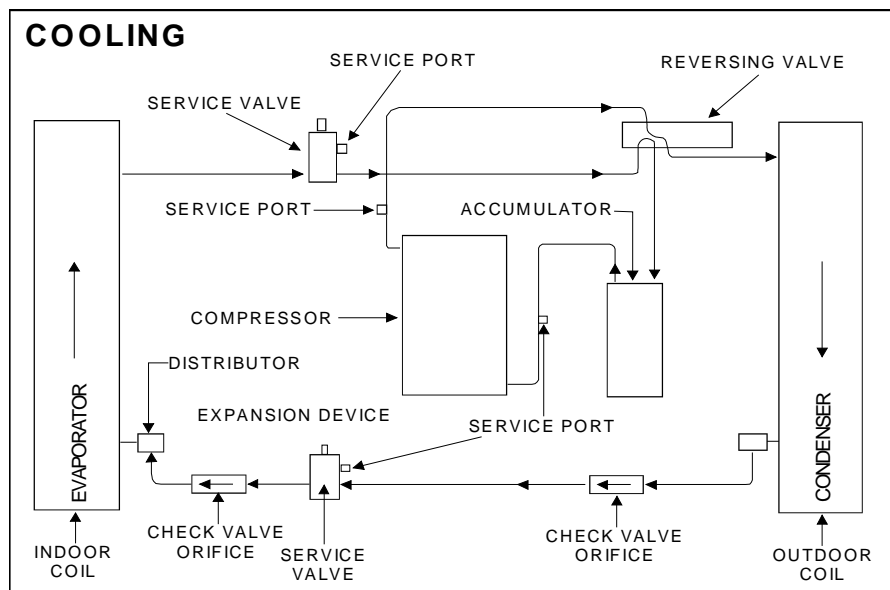

COMPONENTS

1. **Contactors** - This control is activated (closed) by the room thermostat for both heating and cooling. The contactor has a 24V coil and supplies power to the compressor and outdoor fan motor.
2. **Crankcase Heater** – This item is “ON” whenever power is supplied to the unit and the crankcase heater thermostat is closed. Crankcase heater thermostat closes at 67° and opens at 85°. It warms the compressor crankcase thereby preventing liquid migration and subsequent compressor damage. The insert type heater is self regulating. It is connected electrically to the contactor L1 and L2 terminals.
3. **Condenser Motor** - This item is activated by the contactor during heating and cooling, except during defrost and emergency heat operation.
4. **Compressor** - This item is activated by the contactor for heating and cooling, except during emergency heat. It is protected by an internal overload.
5. **Contactors Relay** - This control is activated by the thermostat (24V coil) and supplies power to the contactor.
6. **Defrost Control** - The Defrost control provides time/temperature initiation and termination of the defrost cycle. When a Defrost cycle is initiated, the defrost control shifts the reversing valve to “cooling” mode, stops the outdoor fan and brings on supplemental heat. Normally, a Defrost cycle will take only 2-3 minutes unless system is low on charge or outdoor conditions are severe. (Windy and cold.) The defrost control also provides for a 3 minute off cycle compressor delay.
7. **Outdoor Thermostat** - These optional controls are used to prevent full electric heater operation at varying outdoor ambient (0° F-to 45° F). They are normally open above their set points and closed below to permit staging of indoor supplement heater operation. If the outdoor ambient temperature is below 0° F (-18° C) with 50% or higher RH, an outdoor thermostat (OT) must be installed and set at (0°) on the dial. Failure to comply with this requirement may result in damage to the product which may not be covered by the manufacturer’s warranty.
8. **Reversing Valve Coil** - This coil is activated by the thermostat, in the cooling mode and during defrost. It positions the reversing valve pilot valve for cooling operation.
9. **Indoor Blower Motor**

This item is activated by the room thermostat by COOLING/HEATING or FAN ON position. The motor is energized through the EBTDR for PSC motors.

Units with X-13 Motors Only

The X-13 model indoor blower motor is activated by the room thermostat by COOLING/HEATING or FAN ON position. The motor is energized by a 24 volt control signal (from thermostat Y, G or W) for X-13 motors. X-13 motors are constant torque motors with very low power consumption.

(See **Air Flow Measurement and Adjustment** for speed adjustment instructions).

10. **Blower Interlock Relay** - This relay is used to energize the blower during the electric heat operation. Some room thermostats do not energize the motor during electric heat. This relay insures blower operation when the room thermostat energizes heat. This relay has a 240 volt coil and an 8 amp contact relay. This relay is energized by the electric heat kit sequencer.

EXPLANATION AND GUIDANCE (HEAT PUMP)

The heat pump is a relatively simple device. It operates exactly as a Summer Air Conditioner unit when it is on the cooling cycle. Therefore, all the charts and data for service that apply to summer air conditioning apply to the heat pump when it is on the cooling cycle, and most apply on the heating cycle except that “condenser” becomes “evaporator”, “evaporator” becomes “condenser”, “cooling” becomes “heating”.

When the heat pump is on the heating cycle, it is necessary to redirect the refrigerant flow through the refrigerant circuit external to the compressor. This is accomplished with a reversing valve. Thus, the hot discharge vapor from the compressor is directed to the indoor coil (evaporator on the cooling cycle) where the heat is removed, and the vapor condenses to liquid. It then goes through the expansion device to the outdoor coil (condenser on the cooling cycle) where the liquid is evaporated, and the vapor goes to the compressor.

When the solenoid valve coil is operated either from heating to cooling or vice versa, the piston in the reversing valve to the low pressure (high pressure) reverse positions in the reversing valve.

Figure 7 shows a schematic of a heat pump on the cooling cycle and the heating cycle. In addition to a reversing valve, a heat pump is equipped with an expansion device and check valve for the indoor coil, and similar equipment for the outdoor coil. It is also provided with a defrost control system.

The expansion devices are flowrator distributors and perform the same function on the heating cycle as on the cooling cycle. The flowrator distributors also act as check valves to allow for the reverse of refrigerant flow.

When the heat pump is on the heating cycle, the outdoor coil is functioning as an evaporator. The temperature of the refrigerant in the outdoor coil must be below the temperature of the outdoor air in order to extract heat from the air. Thus, the greater the difference in the outdoor temperature and the outdoor coil temperature, the greater the heating capacity of the heat pump. This phenomenon is a characteristic of a heat pump. It is a good practice to provide supplementary heat for all heat pump installations in areas where the temperature drops below 45° F. It is also a good practice to provide sufficient supplementary heat to handle the entire heating requirement should there be a component failure of the heat pump, such as a compressor, or refrigerant leak, etc.

Since the temperature of the liquid refrigerant in the outdoor coil on the heating cycle is generally below freezing point, frost forms on the surfaces of the outdoor coil under certain weather conditions of temperature and relative humidity. Therefore, it is necessary to reverse the flow of the refrigerant to provide hot gas in the outdoor coil to melt the frost accumulation. This is accomplished by reversing the heat pump to the cooling cycle. At the same time, the outdoor fan stops to hasten the temperature rise of the outdoor coil and lessen the time required for defrosting. The indoor blower continues to run and the supplementary heaters are energized.

DEFROST CONTROL

During operation the power to the circuit board is controlled by a temperature sensor, which is clamped to a feeder tube entering the outdoor coil. Defrost timing periods of 30, 60 and 90 minutes may be selected by setting the circuit board jumper to 30, 60 and 90 respectively. Accumulation of time for the timing period selected starts when the sensor closes (approximately $34 \pm 5^\circ \text{F}$), and when the wall thermostat calls for heat. At the end of the timing period, the unit's defrost cycle will be initiated provided the sensor remains closed. When the sensor opens (approximately 60°F), the defrost cycle is terminated and the timing period is reset. If the defrost cycle is not terminated due to the sensor temperature, a twelve minute override interrupts the unit's defrost period.

SUGGESTED FIELD TESTING/TROUBLE SHOOTING

1. Run unit in the heating mode (room thermostat calling for heat).
2. Check unit for proper charge. **Note: Bands of frost on the condenser coil indicate low refrigerant charge.**
3. Shut off power to unit.
4. Disconnect outdoor fan by removing the outdoor fan motor wire from "DF2" on defrost control.
5. Restart unit and allow frost to accumulate.
6. After a few minutes of operation, the unit's defrost thermostat should close. To verify this, check for 24 volts between "DFT" and "C" on board. If the temperature at the thermostat is less than 28°F and the thermostat is open, replace the unit's defrost thermostat, as it is defective.
7. When the unit's defrost thermostat has closed, short the test pins on the defrost board until the reversing valve shifts, indicating defrost. This should take up to 22 seconds depending on what timing period the control is set on. After defrost initiation, the short must instantly be removed or the unit's defrost period will only last 3 seconds.
8. The control is shipped from the factory with the compressor delay option selected. This will de-energize the compressor contactor for 30 seconds on defrost initiation and defrost termination. If the jumper is set to Normal, the compressor will continue to run during defrost initiation and defrost termination. The control will also ignore the low pressure switch connected to R-PS1 and PS2 for 5 minutes upon defrost initiation and 5 minutes after defrost termination.
9. After the unit's defrost thermostat has terminated, check the defrost thermostat for 24 volts between "DFT" and "C". The reading should indicate 0 volts (open sensor).
10. Shut off power to unit.
11. Replace outdoor fan motor lead to terminal "DF2" on defrost board and turn on power.

AIR FLOW MEASUREMENT AND ADJUSTMENT

After reviewing section on DUCTING, proceed with airflow measurements and adjustments. Unit's blower curves (in Specification Sheets) are based on external static pressure (ESP, in. of W.C.). The duct openings on the unit are considered internal static pressure, so as long as ESP is maintained, the unit will deliver the proper air up to the maximum static pressure listed for the CFM required by the application (i.e. home, building, etc.)

In general 400 CFM per ton of cooling capacity is a rule of thumb. Some applications depending on the sensible and latent capacity requirements may need only 350 CFM or up to 425 CFM per ton. Check condition space load requirements (from load calculations) and equipment expanded ratings data to match CFM and capacity.

After unit is set and ducted, verify ESP with a 1" inclined manometer with pitot tubes or a Magnahelic gauge and confirm CFM to blower curves in the specification sheets. All units have three speed blower motors. If low speed is not utilized, the speed tap can be changed to medium or high speed. Never run CFM below 350 CFM per ton, evaporator freezing or poor unit performance is possible.

ADJUSTING SPEED TAP FOR INDOOR BLOWER MOTOR

PSC Motor

Adjust the CFM for the unit by changing the speed tap of the indoor blower motor at the EBTD "com" connection with one of the speed taps on "M1" or "M2". (Black-High Speed, Blue-Medium Speed, Red-Low Speed.)

X-13 Motor

The blower motor speed for the X-13 motor is controlled by three 24V low voltage leads: green, yellow, and white. The green lead sets the speed for fan-only mode. The yellow lead sets the speed for cooling and heat pump heating mode (if applicable). The white lead sets the speed for electric heat mode (emergency heat and second stage heat, if applicable).

The leads are factory connected as follows: Green to T1, Yellow to T2, and White to T3. T1 is the low speed setting and is dedicated to fan-only mode. T2 is medium speed cooling and T3 is medium speed heating. T4 is high speed cooling and T5 is high speed heating. To adjust the blower speed, move the yellow and/or white wires to T4 and T5.

NOTE: If more than one lead is energized at the same time, the motor will use the higher speed setting.

See CFM vs ESP tables in this manual.

SUPERHEAT CAN BE DETERMINED AS FOLLOWS:

1. Read suction pressure. Determine Saturated Suction Temperature from tables or pressure gauge saturated temperature scale (R-410A).
2. Read suction line temperature.
3. Use the following formula:

$$\text{SUPERHEAT} = \text{SUCTION LINE TEMP} - \text{SAT. SUCTION TEMP.}$$

SATURATED SUCTION PRESSURE TEMPERATURE CHART	
Suction Pressure	Saturated Suction Temperature °F
PSIG	R-410A
50	1
52	3
54	4
56	6
58	7
60	8
62	10
64	11
66	13
68	14
70	15
72	16
71	17
76	19
78	20
80	21

TABLE 5
Suction Pressure Temperature (R-410A)

SUBCOOLING = SAT. LINE TEMP - LIQUID LINE TEMP.

SATURATED LIQUID PRESSURE TEMPERATURE CHART	
Liquid Pressure	Saturated Liquid Temperature °F
PSIG	R-410A
200	70
210	73
220	76
225	78
235	80
245	83
255	85
265	88
275	90
285	92
295	95
305	97
325	101
355	108
375	112
405	118

TABLE 6
Liquid Pressure Temperature (R-410A)

ELECTRIC HEAT INSTALLATION & ADJUSTMENT

This series of electric cooling and heat pump package equipment is designed to accept a field installed electric heat kit. The unit is equipped to easily install the HKR Series Electric Heat Kit. Full Installation Instructions are included in this kit. Please use this document for guidance in field equipping the package unit with electric heat.

Choose the heat kit that fits the application for the specific installation. Permanently mark the unit's nameplate with the model being installed. High and low voltage connections are detailed in the heat kit instructions.

Indoor Blower motor speed tap selection may need to be modified to accommodate normal continuous operation to prevent a nuisance trip. See following table.

GPC/GPH13(24-60) Models					
Unit Model Number	Electric Heat KW				
	5	8	10	15	20
GPC/GPH1324H41**	M _(F)	M _(F)	M _(F)	H	na
GPC/GPH1330H41**	L _(F)	L _(F)	L _(F)	M	na
GPC/GPH1336H41**	M _(F)	M _(F)	M _(F)	H	na
GPC/GPH1342H41**	L _(F)	L _(F)	M	M	H
GPC/GPH1348H41**	M _(F)	M _(F)	M _(F)	M _(F)	H
GPC1349H41**	M _(F)	M _(F)	M _(F)	M _(F)	H
GPC/GPH1360H41**	2 _(F)	2 _(F)	2 _(F)	2 _(F)	2 _(F)

H / 3 - High; M / 2 - Medium; L / 1 - Low
Speed Taps Description: H/M/L - PSC: 3/2/1 - X-13

GPC/GPH14(24-60) Models					
Unit Model Number	Electric Heat KW				
	5	8	10	15	20
GPC/GPH1424H41**	T3	T3	T3	T5	NA
GPC/GPH1430H41**	T3	T3	T3	T5	NA
GPC/GPH1436H41**	T3	T3	T3	T5	NA
GPC/GPH1442H41**	T3	T3	T3	T3	T5
GPC/GPH1448H41**	T3	T3	T3	T3	T3
GPC/GPH1460H41**	T3	T3	T3	T3	T3

T1 - Fan Only; T2 - Normal Speed Cooling
T3 - Normal Speed Heating
T4 - High Speed Cooling; T5 - High Speed Heating

MAINTENANCE



The Self Contained Package Air Conditioner and Heat Pump should operate for many years without excessive service calls if the unit is installed properly. However it is recommended that the homeowner inspect the unit before a seasonal start up. The coils should be free of debris so adequate airflow is achieved. The return and supply registers should be free of any obstructions. The filters should be cleaned or replaced. These few steps will help to keep the product up time to a maximum. The Troubleshooting Chart (on page 11) should help in identifying problems if the unit does not operate properly.

SERVICE

THE FOLLOWING INFORMATION IS FOR USE BY QUALIFIED SERVICE AGENCY ONLY: OTHERS SHOULD NOT ATTEMPT TO SERVICE THIS EQUIPMENT.

Common Causes of Unsatisfactory Operation of Heat Pump on the Heating Cycle.

Inadequate Air Volume Through Indoor Coil

When a heat pump is in the heating cycle, the indoor coil is functioning as a condenser. The return air filter must always be clean, and sufficient air volume must pass through the indoor coil to prevent excessive discharge pressure, and high pressure cut out.

Outside Air Into Return Duct

Do not introduce cold outside air into the return duct of a heat pump installation. Do not allow air entering the indoor coil to drop below 65° F. Air below this temperature will cause low discharge pressure, thus low suction pressure, and excessive defrost cycling resulting in low heating output. It may also cause false defrosting.

Undercharge

An undercharged heat pump on the heating cycle will cause low discharge pressure resulting in low suction pressure and frost accumulation on the outdoor coil.

Poor "Terminating" Sensor Contact

The unit's defrost terminating sensor must make good thermal contact with the outdoor coil tubing. Poor contact may not terminate the unit's defrost cycle quickly enough to prevent the unit from cutting out on high discharge pressure.

Malfunctioning Reversing Valve

This may be due to:

1. **Solenoid not energized** - In order to determine if the solenoid is energized, touch the nut that holds the solenoid cover in place with a screwdriver. If the nut magnetically holds the screwdriver, the solenoid is energized and the unit is in the cooling cycle.
2. **No voltage at unit's solenoid** - Check unit voltage. If no voltage, check wiring circuit.
3. **Valve will not shift:**
 - a. **Undercharged** - check for leaks;
 - b. **Valve Body Damaged** - Replace valve;
 - c. **Unit Properly Charged** - If it is on the heating cycle, raise the discharge pressure by restricting airflow through the indoor coil. If the valve does not shift, tap it **lightly** on both ends with a screwdriver handle. **Do Not Tap The Valve Body**. If the unit is on the cooling cycle, raise the discharge pressure by restricting airflow through the outdoor coil. If the valve does not shift after the above attempts, cut the unit off and wait until the discharge and suction pressure equalize, and repeat above steps. If the valve does not shift, replace it.

GPC/GPH13**H41 BLOWER PERFORMANCE

Model	Speed	Volts	E.S.P (In. of H ₂ O)								
			0.1	0.2	0.3	0.4	0.5	0.6	0.7	0.8	
GPC1324H41** GPH1324H41**	Low	230	CFM	680	640	590	555	505	440	340	-
			WATTS	155	150	145	140	130	120	110	-
	Med	230	CFM	895	855	815	755	700	630	545	390
			WATTS	230	220	215	205	195	180	170	145
	High	230	CFM	1,185	1,130	1,070	1,010	930	850	760	650
			WATTS	350	340	325	310	295	280	265	245
GPC1330H41** GPH1330H41**	Low	230	CFM	1,150	1,080	1,025	975	925	845	-	-
			WATTS	340	330	315	305	295	280	-	-
	Med	230	CFM	1,335	1,275	1,205	1,135	1,075	985	910	845
			WATTS	425	415	400	385	370	350	330	310
	High	230	CFM	1,435	1,355	1,290	1,210	1,130	1,040	960	885
			WATTS	485	465	455	435	415	400	385	370
GPC1336H41** GPH1336H41**	Low	230	CFM	1,180	1,125	1,075	1,020	955	875	655	-
			WATTS	335	325	315	305	295	275	240	-
	Med	230	CFM	1,350	1,280	1,205	1,130	1,050	985	910	845
			WATTS	435	420	405	385	375	350	330	310
	High	230	CFM	1,450	1,370	1,290	1,205	1,130	1,040	960	885
			WATTS	495	480	465	440	425	400	385	370
GPC1342H41** GPH1342H41** GPC1349H41**	Low	230	CFM	1,425	1,410	1,355	1,310	1,245	1,170	1,080	-
			WATTS	450	445	430	420	405	390	370	-
	Med	230	CFM	1,620	1,595	1,545	1,485	1,425	1,345	1,250	1,160
			WATTS	550	540	525	510	495	475	450	425
	High	230	CFM	1,945	1,935	1,875	1,800	1,730	1,635	1,535	1,440
			WATTS	765	755	735	715	695	670	640	615
GPC1348H41** GPH1348H41**	Low	230	CFM	1,425	1,410	1,355	1,310	1,245	1,170	1,080	-
			WATTS	450	445	430	420	405	390	370	-
	Med	230	CFM	1,720	1,660	1,585	1,520	1,460	1,365	1,270	-
			WATTS	560	555	540	530	520	490	470	-
	High	230	CFM	2,110	2,060	1,980	1,895	1,795	1,705	1,590	1,500
			WATTS	785	780	765	745	720	705	665	625
GPC1360H41** GPH1360H41**	T1	230	CFM	1,775	1,635	1,645	1,515	1,510	1,450	1,430	1,400
			WATTS	395	420	435	445	455	465	470	475
	T2/T3	230	CFM	1,845	1,790	1,715	1,685	1,590	1,580	1,530	1,500
			WATTS	490	505	520	535	550	560	570	575
	T4/T5	230	CFM	2,025	1,900	1,840	1,780	1,725	1,650	1,620	1,580
			WATTS	575	595	620	630	645	655	660	670

NOTES:

1. Data shown is dry coil. Wet coil pressure drop is approx.
2. 0.1" H₂O, for 2 row indoor coil; 0.2" H₂O, for 3 row indoor coil; and 0.3" H₂O, for 4 row indoor coil.
3. Data shown does not include filter pressure drop, approx. 0.08" H₂O.
4. Reduce airflow by 2% for 208V operation.

GPC/GPH14**H41 BLOWER PERFORMANCE

Model	Speed	Volts		E.S.P (In. of H ₂ O)							
				0.1	0.2	0.3	0.4	0.5	0.6	0.7	0.8
GPC1424H41** GPH1424H41**	T1	230	CFM	934	759	755	638	581	489	-	-
			WATTS	95	77	76	73	83	90	-	-
	T2,T3	230	CFM	990	837	801	744	696	652	601	-
			WATTS	107	94	105	110	119	133	142	-
	T4, T5	230	CFM	1061	989	947	925	876	-	-	-
			WATTS	126	134	146	158	169	-	-	-
GPC1430H41** GPH1430H41**	T1	230	CFM	1022	929	894	829	797	748	695	643
			WATTS	116	114	126	134	144	156	168	173
	T2,T3	230	CFM	1103	1063	1012	962	937	-	-	-
			WATTS	142	154	165	173	185	-	-	-
	T4, T5	230	CFM	1285	1240	1202	1163	1124	1076	1046	1003
			WATTS	205	218	231	244	257	268	280	288
GPC1436H41** GPH1436H41**	T1	230	CFM	1234	1111	1071	1024	933	922	-	-
			WATTS	144	140	152	164	179	183	-	-
	T2,T3	230	CFM	1287	1232	1186	1133	1099	1053	-	-
			WATTS	162	175	187	201	213	221	-	-
	T4, T5	230	CFM	1381	1325	1277	1233	1181	1144	-	-
			WATTS	195	203	217	233	247	258	-	-
GPC1442H41** GPH1442H41**	T1	230	CFM	1272	1197	1145	1106	1055	998	947	906
			WATTS	160	168	183	191	211	220	230	243
	T2,T3	230	CFM	1357	1297	1244	1194	1147	1099	1049	1008
			WATTS	188	202	213	228	245	255	267	284
	T4, T5	230	CFM	1537	1478	1431	1386	1336	1293	1253	1208
			WATTS	244	258	274	288	303	317	329	341
GPC1448H41** GPH1448H41**	T1	230	CFM	1418	1383	1349	1312	1275	1228	1178	1141
			WATTS	242	258	273	282	299	308	320	338
	T2,T3	230	CFM	1175	1635	1645	1515	1510	1450	1430	1400
			WATTS	395	420	435	445	455	465	470	475
	T4, T5	230	CFM	1845	1790	1715	1685	1590	1580	1530	1500
			WATTS	490	505	520	535	550	560	570	575
GPC1460H41** GPH1460H41**	T1, T2, T3	230	CFM	1775	1635	1645	1515	1510	1450	1430	1400
			WATTS	395	420	435	445	455	465	470	475
	T4, T5	230	CFM	2025	1900	1840	1780	1725	1650	1620	1580
			WATTS	575	595	620	630	645	655	660	670

NOTES:

1. Data shown is dry coil. Wet coil pressure drop is approx.
2. 0.1" H₂O, for 2 row indoor coil; 0.2" H₂O, for 3 row indoor coil; and 0.3" H₂O, for 4 row indoor coil.
3. Data shown does not include filter pressure drop, approx. 0.08" H₂O.
4. Reduce airflow by 2% for 208V operation.

TROUBLESHOOTING CHART



WARNING

HIGH VOLTAGE!

DISCONNECT ALL POWER BEFORE SERVICING OR INSTALLING THIS UNIT. MULTIPLE POWER SOURCES MAY BE PRESENT. FAILURE TO DO SO MAY CAUSE PROPERTY DAMAGE, PERSONAL INJURY OR DEATH.



SYMPTOM	POSSIBLE CAUSE	REMEDY
High head - low suction	a. Restriction in liquid line or flowrator	a. Remove or replace with proper size flowrator.
High head - high or normal suction	a. Dirty condenser coil b. Overcharged c. Condenser fan not running	a. Clean coil b. Correct System charge c. Repair or Replace
Low head - high suction	a. In correct flowrator b. Defective compressor valves c. Flowrator not seating properly	a. Replace with correct flowrator b. Replace compressor c. Check for debris under flowrator or deformed flowrator. Remove debris or replace flowrator.
Unit will not run	a. Power off or loose electrical connection b. Thermostat out of calibration set too high c. Defective contactor d. Blown fuses or tripped breaker e. Transformer defective f. High or low pressure control open (Optional) g. Compressor overload contacts open	a. Check for unit voltage at contactor in unit b. Reset c. Check for 24 volts at contactor coil replace if contacts are open d. Replace fuse or reset breaker Check wiring - replace transformer f. Reset high pressure control or check unit charge High pressure control opens at 610 psig Low pressure control opens at 22 psig g. Replace compressor NOTE: Wait at least 2 hours for overload to reset
Condenser fan runs, compressor doesn't	a. Loose connection b. Compressor stuck, grounded or open winding open internal overload c. Low voltage connection d. Capacitor weak, open, or shorted	a. Check for unit voltage at compressor check & tighten all connections b. Wait at least 2 hours for overload to reset If still open, replace the compressor. c. At compressor terminals, voltage must be within 10 % of nameplate volts when unit is operating d. Check capacitor. If defective, replace.
Low suction - cool compressor Iced evaporator coil	a. Low indoor airflow	a. Increase speed of blower or reduce restriction - replace air filters
Compressor short cycles	a. Defective overload protector b. Unit cycling on low pressure control c. High pressure switch cuts out	a. Replace - check for correct voltage b. Check refrigerant charge and / or airflow c. Check airflow (Indoor & outdoor)
Registers sweat	a. Low airflow	a. Increase speed of blower or reduce restriction replace air filters
High suction pressure	a. Excessive load b. Defective compressor c. Reversing valve not seating properly.	a. Recheck load calculation b. Replace c. Replace
Insufficient cooling	a. Improperly sized unit b. Improper airflow c. Incorrect refrigerant charge. d. Incorrect voltage	a. Recalculate load b. Check - should be approximately 400 CFM per ton c. Charge per procedure attached to unit service panel d. At compressor terminals, voltage must be within 10% of nameplate volts when unit is operating
Evaporator coil freezing or frosting	a. Low airflow b. Low refrigerant charge c. Operating unit in cooling mode below 65°F outdoor temperature	a. Check - should be approximately 400 CFM per ton, dirty air filters, all duct outlets open b. Properly charge unit c. Install or check low ambient control, should be open below 65°F outdoor temperature

NOTE: SPECIFICATIONS AND PERFORMANCE DATA LISTED HEREIN ARE SUBJECT TO CHANGE WITHOUT NOTICE.

Quality Makes the Difference!

All of our systems are designed and manufactured with the same high quality standards regardless of size or efficiency. We have designed these units to significantly reduce the most frequent causes of product failure. They are simple to service and forgiving to operate. We use quality materials and components. Finally, every unit is run tested before it leaves the factory. That's why we know. . . **There's No Better Quality.**

Visit our website at www.goodmanmfg.com for information on:

- Products
- Warranties
- Customer Service
- Parts
- Contractor Programs and Training
- Financing Options

© 2010-2012 Goodman Manufacturing Company, L.P.