

# HORIZONTAL TWO-WAY COIL

## INSTALLATION INSTRUCTIONS


### Important Safety Instructions

The following symbols and labels are used throughout this manual to indicate immediate or potential safety hazards. It is the owner's and installer's responsibility to read and comply with all safety information and instructions accompanying these symbols. Failure to heed safety information increases the risk of personal injury, property damage, and/or product damage.

**WARNING**

**HIGH VOLTAGE!**

Disconnect ALL power before servicing. Multiple power sources may be present. Failure to do so may cause property damage, personal injury or death.



**WARNING**

ONLY individuals meeting the requirements of an "Entry Level Technician", at a minimum, as specified by the Air Conditioning, Heating and Refrigeration Institute (AHRI) may use this information. Attempting to install or repair this unit without such background may result in product damage, personal injury, or death.

### Shipping Inspection

Upon receiving the product, inspect it for damage from shipment. Shipping damage, and subsequent investigation is the responsibility of the carrier. Verify the model number, specifications, electrical characteristics, and accessories are correct prior to installation. The distributor or manufacturer will not accept claims from dealers for transportation damage or installation of incorrectly shipped units.

### Codes & Regulations

This product is designed and manufactured to comply with national codes. Installation in accordance with such codes and/or prevailing local codes/regulations is the responsibility of the installer. The manufacturer assumes no responsibility for equipment installed in violation of any codes or regulations.

**The United States Environmental Protection Agency (EPA) has issued various regulations regarding the introduction and disposal of refrigerants. Failure to follow these regulations may harm the environment and can lead to the imposition of substantial fines.** Should you have any questions please contact the local office of the EPA.

### Replacement Parts

When reporting shortages or damages, or ordering repair parts, give the complete product model and serial numbers as stamped on the product. Replacement parts for this product are available through your contractor or local distributor. For the loca-

tion of your nearest distributor consult the white business pages, the yellow page section of the local telephone book or contact:

CONSUMER AFFAIRS  
GOODMAN MANUFACTURING COMPANY, L.P.  
7401 SECURITY WAY  
HOUSTON, TEXAS 77040  
877-254-4729

### Pre-Installation Instructions

Carefully read all instructions for the installation prior to installing product. Make sure each step or procedure is understood and any special considerations are taken into account before starting installation. Assemble all tools, hardware and supplies needed to complete the installation. Some items may need to be purchased locally. Make sure everything needed to install the product is on hand before starting.

### Application Information

Install this coil upstream (discharge air) of the furnace and install downstream (return air) of the air handler. This coil is bi-directional coil and can be installed in either the left or right direction. Determine the coil direction by the side that allows the best access.

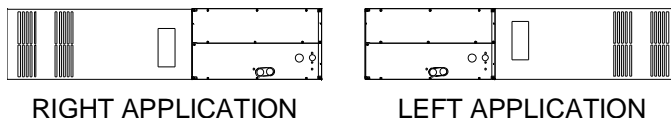


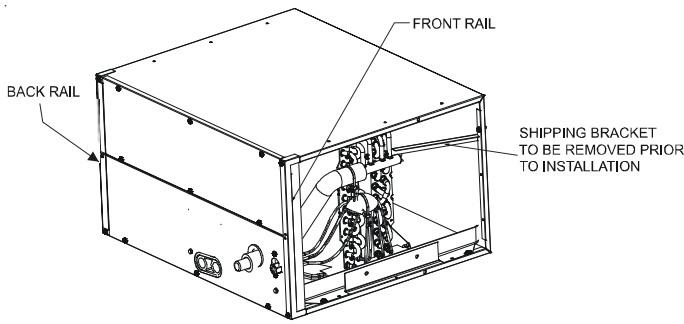
Figure 1  
Front View (for Right & Left Hand Application)

There is no conversion required to reverse from right to left application. Attach the duct flanges to the discharge side of the unit. If the coil and furnace combination are not similar in depth and width, use a field-supplied transition to center the furnace and coil openings (see figure 3). The supplied Z-bracket attachment should be used to attach the coil to a narrower furnace when the furnace is one size smaller than the coil (i.e. coil height = 17.5-inches and furnace width = 14-inches) (See figure 3). Figure 3a indicates incorrect coil/furnace attachment method.

### Duct Flange Attachment

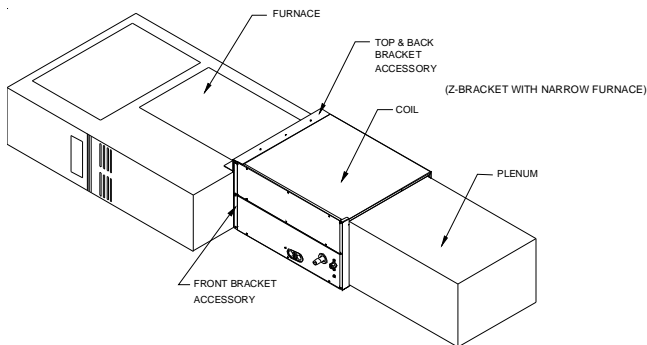
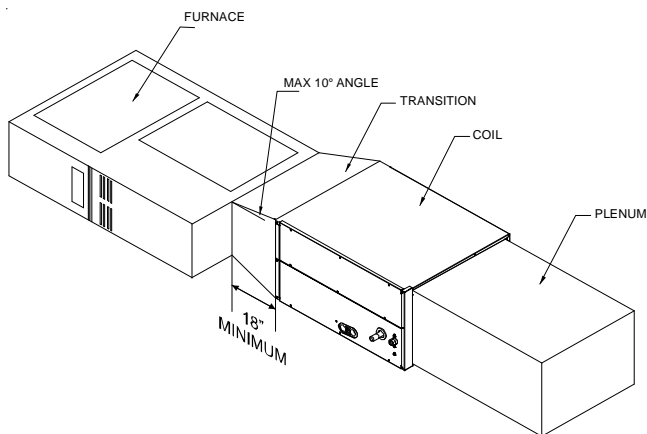
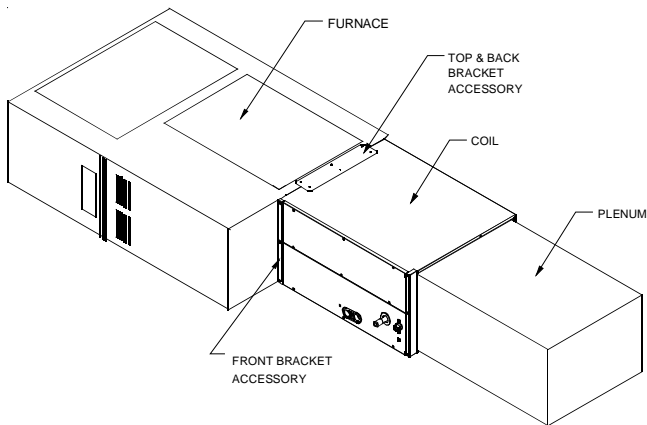
1. Remove the shipping bracket spanning the A-Coil apex to the rear of the wrapper on all models prior to installation.
2. The bottom duct flange for the supply plenum side is shipped unattached. Carefully insert the flange into bottom rail and use a 5/16" screw to attach at the middle of the flange.



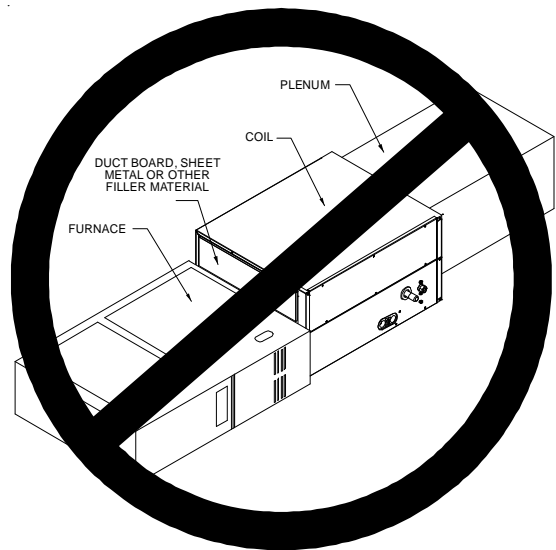


**Figure 2**  
**Horizontal Right Application**

3. Using the hardware and brackets provided, attach the coil to the furnace then attach the plenum to the coil (Figure 3).



**Figure 3**  
**Furnace, Coil and Plenum Installation**



**Figure 3a**  
**Incorrect Furnace, Coil and Plenum Installation**

Using tape or mastic seal between the coil and furnace and the coil and plenum.

### **Condensate Drain Piping**

When coils are installed above ceilings, or in other locations where damage from condensate overflow may occur, it is **MANDATORY** to install a field-fabricated auxiliary drain pan under the coil cabinet enclosure. Drain lines from the auxiliary pan must be installed and terminated so that the homeowner can see water discharges.

The coil drain pan has a primary and an optional secondary drain with 3/4" NPT female connections. The connectors required can be 3/4" NPT male either PVC or metal pipe and should be hand tightened to a torque of no more than 37 in-lbs. to prevent damage to the drain pan connection. An insertion depth between .355 to .485 inches (3-5 turns) should be expected at this torque. If using a copper drain line, solder a short piece of pipe to the connector before installing a drain fitting. **DO NOT** over torque the 3/4" copper connector to the plastic drain connection.

1. Ensure drain pan hole is **NOT** obstructed.
2. To prevent potential sweating and dripping on finished space, it may be necessary to insulate the condensate drain line located inside the building. Use Armaflex® or similar material.

A Secondary Condensate Drain Connection has been provided for areas where the building codes require it. Pitch the drain line 1/4" per foot to provide free drainage. Insulate drain lines (primary and secondary) located inside the building to prevent sweating. Install a condensate trap in the primary drain line to ensure proper drainage. If the secondary line is required, run the line separately from the primary drain and end it where it can be easily seen.

**NOTE:** Water coming from this line means the coil primary drain is plugged and needs clearing.

## CAUTION

If secondary drain is not installed, the secondary access must be plugged.

**NOTE:** Trapped lines are required by many local codes. In the absence of any prevailing local codes, please refer to the requirements listed in the Uniform Mechanical Building Code.

A drain trap in a **draw-through** application prevents air from being drawn back through the drain line during fan operation thus preventing condensate from draining, and if connected to a sewer line to prevent sewer gases from being drawn into the airstream during blower operation. In a **blow-through** application the drain trap prevents conditioned air from escaping. It is permissible in this application to use a shallow trap design sometimes referred to as a running trap.

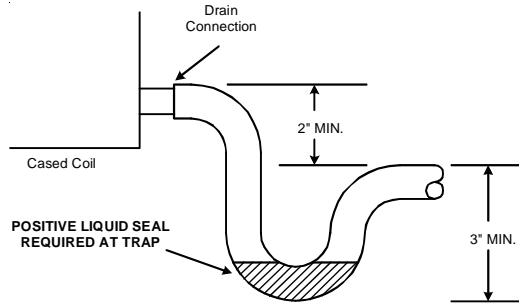


Figure 4  
Condensate Drain Trap

The depth of a running trap (Figure 5) should be either 1" or a depth that permits unrestricted condensate drainage without excessive air discharge.

Field experience has shown condensate drain traps with an open vertical Tee between the air handler and the condensate drain trap can improve condensate drainage in some applications, but may cause excessive air discharge out of the open Tee. The manufacturer does not prohibit this type of drain but we also do not recommend it due to the resulting air leakage. Regardless of the condensate drain design used, it is the installer's responsibility to ensure the condensate drain system is of sufficient design to ensure proper condensate removal from the coil drain pan.

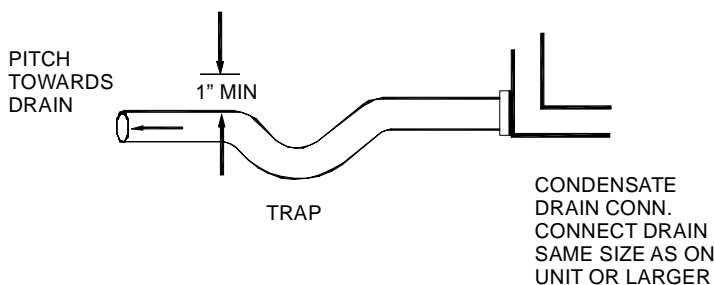


Figure 5  
Running Trap

## Horizontal Coil Water Blower-Off Bracket

CHPF4860 coils are shipped with an accessory kit containing a sheet metal bracket. For horizontal-left applications where the airflow may exceed 1600 CFM, this bracket must be installed on the left side of the drain pan as shown in Figure 6.



Figure 6  
Horizontal Blow-Off Bracket

## Refrigerant Lines

### WARNING

A quenching cloth is strongly recommended to prevent scorching or marring of the equipment finish when welding close to the painted surfaces. Use brazing alloy of 5% minimum silver content.

All cut ends are to be round, burr free, and cleaned. Any other condition increases the chance of a refrigerant leak. Use a pipe cutter to remove the closed end of the spun closed suction line.

To avoid overheating after brazing, quench all welded joints with water or a wet rag.

For the correct tubing size, follow the specification for the condenser/heat pump

### WARNING

The coil is shipped under pressure. Follow these instructions to prevent injury.

### CAUTION

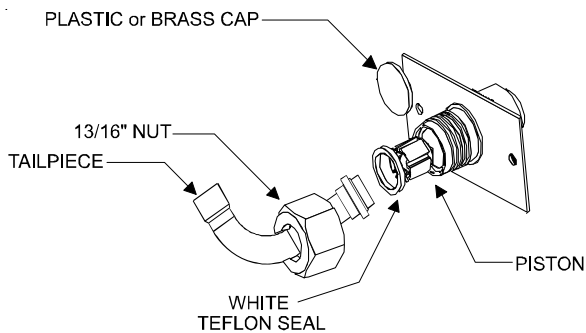
Applying too much heat to any tube can melt the tube. Torch heat required to braze tubes of various sizes must be proportional to the size of the tube. Service personnel must use the appropriate heat level for the size of the tube being brazed.

**NOTE:** Tubes of smaller size require less heat to bring the tube to brazing temperature before adding brazing alloy. The use of a heat shield when brazing is recommended to avoid burning the serial plate or the finish on the unit.

## Special Instructions

This coil comes equipped with a check style flowrator for refrigerant management. For most installations with matching applications, no change to the flowrator orifice is required. However, in mix-matched applications, a flowrator change may be required. See the Piston Kit Chart or consult your local distributor for details regarding mix-matched orifice sizing. If the mix-match application requires a different piston size, change the piston in the distributor on the indoor coil before installing the coil and follow the procedure shown below.

1. Loosen the 13/16 nut **1 TURN ONLY** to allow high pressure tracer gas to escape. No gas indicates a possible leak.
2. After the gas has escaped, remove the nut and discard the plastic or brass cap.
3. Remove the check piston to verify it is correct and then replace the piston. See piston kit chart in instructions.
4. Use a tube cutter to remove the spin closure on the suction line.
5. Slide the 13/16 nut into place on the tailpiece supplied in the literature bag or with the unit.
6. Braze tailpiece to the line set liquid tube.



**Figure 7**  
**Flowrator**

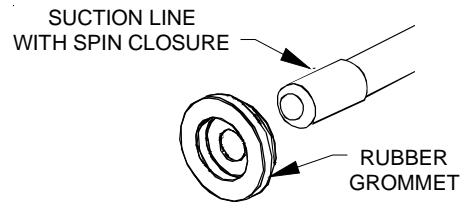
7. Insert the suction line into the connection, slide the insulation and the rubber grommet at least 18" away from the braze joint. Braze suction line.
8. **AFTER THE TAILPIECE HAS COOLED**, confirm position of the white Teflon® seal and hand tighten the 13/16 nut.
9. Torque the 13/16 nut to 10-25 ft-lbs. or tighten 1/6 turn.



## CAUTION

Excessive torque can cause orifices to stick. Use the proper torque settings when tightening orifices.

10. Replace suction line grommet and insulation.



**Figure 8**  
**Suction Line Grommet**

11. Check fittings for leaks after complete installation. Evacuate and charge on the low side.

**NOTE:** With the piston in the distributor, the seal end should point inside the distributor body and should not be seen when looking into the end of distributor. Make sure the piston is free to rotate, and move up and down in the distributor body.

**IMPORTANT:** Note 2 in the Piston Kit Chart does not apply to CH coils.

## Aluminum Indoor Coil Cleaning (Qualified Servicer Only)

This unit is equipped with an aluminum tube evaporator coil. The safest way to clean the evaporator coil is to simply flush the coil with water. This cleaning practice remains as the recommended cleaning method for both copper tube and aluminum tube residential cooling coils.

An alternate cleaning method is to use one of the products listed in the technical publication **TP-109 (shipped in the literature bag with the unit)** to clean the coils. The cleaners listed are the only agents deemed safe and approved for use to clean round tube aluminum coils. TP-109 is available on the web site in Partner Link > Service Toolkit.

**NOTE:** Ensure coils are rinsed well after use of any chemical cleaners.

NOTE: SPECIFICATIONS AND PERFORMANCE DATA LISTED HEREIN ARE SUBJECT TO CHANGE WITHOUT NOTICE  
Visit our website at [www.daikincomfort.com](http://www.daikincomfort.com), [www.goodmanmfg.com](http://www.goodmanmfg.com) or [www.amana-hac.com](http://www.amana-hac.com) for information on:

- Products
- Customer Services
- Contractor Program and Training
- Warranties
- Parts
- Financing Options

5151 San Felipe, Suite 500, Houston, TX 77056



© 2005-2006, 2009-2013, 2015 Goodman Manufacturing Company, L.P.

is a registered trademark of Maytag Corporation or its related companies and is used under license. All rights reserved.